



NG-CDF BOARD

NATIONAL GOVERNMENT CONSTITUENCIES DEVELOPMENT FUND

HOMABAY TOWN CONSTITUENCY

Kabunde Multipurpose Hall

P.O BOX 240 Homabay, 40300

Email: cdfhomabaytown@ngcdf.go.ke | Website: www.ngcdf.go.ke

Our Ref: HBTC/NG-CDF/PROPOSAL 01/2022/2023

3RD JANUARY, 2023

THE CHIEF EXECUTIVE OFFICER,
NG-CDF BOARD,
HARAMBEE COOPERATIVE SACCO PLAZA, 5TH FLOOR
JUNCTION OF HAILE SELASSIE AVENUE & UHURU HIGHWAY
P.O BOX 46682-00100,
NAIROBI.

Dear Sir,

RE: SUBMISSION OF HOMA BAY TOWN CONSTITUENCY PROJECT PROPOSAL FOR THE YEAR 2022/2023

Further to your letter reference NG-CDF/CEO/NG-CDF CIRCULARS Vol II (033) dated 15th December 2022, I wish to submit the Homabay Town Constituency Project Proposal to the National Government Constituency Development Fund Board for approval and funding.

Kindly find the following attached documents for your expedition:

- NG-CDFC Minutes for 3rd January 2023.
- List of Ongoing projects.
- Third and Fourth schedules.
- Ward report.
- Copies of Bill of Quantities.
- Budget on Administration and recurrent Expenditure.

Yours faithfully,

WILSON OKUMU
FUND ACCOUNT MANAGER
+254 722- 700- 485



Vision: Equitable social-economic development in Homabay Town Constituency





NATIONAL GOVERNMENT CONSTITUENCIES DEVELOPMENT FUND
HOMABAY TOWN CONSTITUENCY
Kabunde Multipurpose Hall
P.O BOX 240 Homabay, 40300
Email: cdfhomabaytown@ngcdf.go.ke | Website: www.ngcdf.go.ke

**HOMA BARY TOWN NATIONAL GOVERNMENT CONSTITUENCY DEVELOPMENT FUND
COMMITTEE 2ND MEETING HELD ON 3RD JANUARY 2023 AT THE NG-CDFC OFFICES – KABUNDE**

MEMBERS PRESENT

- | | |
|---------------------------|----------------------------|
| 1. Harrison Ouko | Chairperson |
| 2. Bugo Agoro Charles | Secretary |
| 3. Betha Hildigard Owenga | Member |
| 4. Richard Ochieng Askari | Member |
| 5. Edith Awuor Obonyo | Member |
| 6. John Onyango | Member |
| 7. Lorna Awuor Okidi | Member |
| 8. Teresa Ochieng | Co -Opted Member |
| 9. Wilson Okumu | Fund Account Manager |
| 10. Jude Wasonga | Deputy County Commissioner |

IN ATTENDANCE

- | | |
|-----------------------|-----------------------|
| 1. Donald Ochieng | Account Assistant |
| 2. Scholastica Wanina | Procurement Assistant |
| 3. Oliver Akinyi | Clerk of Works |

AGENDA

1. Communication from the chairperson
2. Reading and confirmation of the previous Meeting Minutes
3. Matters arising
4. Bursary
5. Preparation, Presentation and Submission of Project Proposal – 2022/2023 FY
6. A.O.B.



MIN.HBTC NG-CDFC 01/01/1/2022/2023: COMMUNICATION FROM THE CHAIRPERSON.

The Chairperson called the meeting to order at 9:30 am after confirming the quorum. He requested Mr. Richard Askari to lead the members in an opening prayer.

The Chairperson on his remarks commended the Fund Account Manager, Mr. Wilson Ogogo for the tireless efforts he has made to ensure Homabay Town Constituency gets a new face in terms of project management picking from where Mr. David Agong had left. He assured the Fund Manager of the NG-CDFC's full support and asked for cooperation and proper communication when called upon by appropriate channels.

MIN.HBTC NG-CDFC 02/01/1/2022/2023: READING AND CONFIRMATION OF THE PREVIOUS MEETING MINUTES

The secretary read out the minutes of the previous meeting held on 20th December 2022. The minutes were confirmed and seconded by Mrs. Edith Awuor and Mr. John Onyango to be true minutes of the meeting held that day.

MIN.HBTC NG-CDFC 03/01/1/2022/2023: MATTERS ARISING

The chairperson commended the members for their tireless participation during the ward meeting as some of them dragged past office working hours.

He further appreciated the Deputy County Commissioner, Mr. Jude Wasonga for helping in mobilization of members of the public during the public participation exercise that was conducted as from **27th December, 2022** to **30th December, 2022**. The DCC had also mobilized the area chiefs and their assistants who showed up for the exercise and greatly contributed to its success.

A report of the ward meeting was tabled to the members and they adopted the report as was presented.

MIN.HBTC NG-CDFC 04/1/1/2022/2023: BURSARY

The Fund Account Manager informed the members that the NG-CDF Board is yet to disburse funds for the 2022/2023 FY. However, the schools would soon be reopening and therefore he urged the members to be proactive and give the correct position to the members of the general public as the office might not be in a position to award bursary to the needy students at the beginning of the new term.

He also advised the members to be guided by the NG-CDF Act in identification of the needy students across the constituency by developing and issuing of bursary forms to the applicants after which the applicants are vetted and forwarded to the NG-CDFC for sponsorship. The members unanimously agreed to embrace the idea to avoid audit queries in the future.

In regards to the fully sponsored needy students' in the constituency, the list is not up to date as some of the students sat for their national exams as some got transferred to different institutions amongst other reasons. The members resolved to send representatives from the committee to visit the beneficiary institutions for manual verification of the fully sponsored students.

MIN.HBTC NG-CDFC 05/1/1/2022/2023: PUBLIC PARTICIPATION.



The Fund Account Manager tabled before the committee a report on public participation conducted between **27th December, 2022** to **30th December, 2022**. The members were in agreement that the exercise was successfully done and the report clearly outlines the needs of the constituents. It was therefore resolved that the report be used for prioritization of projects for funding in the 2022/23 and 2023/24 financial years.

MIN.HBTC NG-CDFC 05/1/1/2022/2023: PUBLIC PARTICIPATION.

The Fund Account Manager tabled before the committee a report on public participation conducted as from **27th to 30th December 2022**. The members were in agreement that the exercise was successfully done and the report clearly outlines the needs of the constituents as captured in the table below:

NO	SCHOOL	ACTIVITY	WARD
1.	Nyanguu Primary School	Construction of administration block consisting of two offices	East Ward
2.	Sinangi Primary School	<ul style="list-style-type: none">• Construction of 4 door latrine• Construction and equipping of 2 No. Classrooms	East Ward
3.	Nyauu Primary School	Renovation of 8no. Classrooms	East Ward



National Government
Constituency Development Fund
Homa Bay Town Constituency
03 JAN 2023
Fund Account Manager
P.O. BOX 140 HOMA BAY, 40300
cdhombabaytown@ngcdf.go.ke

4.	Ndiru Primary School	Renovation of administration block and 2No. Classrooms	East Ward
5.	Roba Primary School	Construction of 2 No. Classrooms	East Ward
6.	Achiero Primary School	Construction and equipping of 2 No classrooms	East Ward
7.	St Pius Ndiru Secondary School	Construction of a Laboratory	East Ward
8.	St. Theresa's Nyauu Girls Secondary School	Construction of a dormitory	East Ward
9.	St.Marys Marindi Girls Secondary School	Purchase of 51 seater school bus	East Ward
10.	Otaro Primary School	Landscaping and fencing of the school compound	East Ward
11.	Nyakune Primary School	Renovation of 3no. Classrooms	West Ward
12.	Nyakahia Mixed Secondary School	Construction Of 60 students capacity science laboratory:	West Ward
13.	Opande Rarage Primary School	Construction 2No. Classrooms	Central Ward
14.	Wiobiero Primary School	Renovation of 5 No. classrooms	Central Ward

It was therefore resolved that the report be used for prioritization of projects for funding in the 2022/23 and 2023/24 financial years.



MIN.HBTC NG-CDFC 06/1/1/2022/2023: ONGOING PROJECTS

The Fund Account Manager tabled before the committee the list of all ongoing projects as was submitted to the Board. *The committee noted that some of the ongoing projects were allocated funds in the previous financial years for construction to completion but due to rise in cost of construction materials, the projects could not be completed as the amounts were not adequate since most competitive bidders quoted relatively higher amounts as compared to what were allocated to the projects.* The Committee therefore resolved to allocate more funds to the projects for completion. It was agreed that the list is true representation of the status of projects. The members resolved to give first priority to the projects for funding to completion in 2022/23 financial year.

MIN.HBTC NG-CDFC 07/1/1/2022/2023: PREPARATION, PRESENTATION AND SUBMISSION OF PROJECT PROPOSAL FOR 2022/2023 FINANCIAL YEAR

The Fund Account Manager reminded the members, that as they prepare to compile the project proposals for submission to the NG-CDF Board, they should adhere to the directives of the NG-CDF Board circular dated **15th December, 2022**, stating that the NG-CDFC should prioritize funding all the ongoing projects to completion before identifying new projects for implementation.

He further informed the members that the 1% of the Monitoring and Evaluation allocation that was set aside for the constituency oversight committee had been reviewed to 1% of the total constituency allocation.

The members deliberated on the status of the ongoing projects after which the members agreed to set aside adequate funds to complete the ongoing projects, guided by the report that had been forwarded to the NG-CDF Board.

The NG-CDFC further deliberated on the ward meetings report and thereafter culminated with the below as the final project proposal for the 2022/2023 FY;

S/N	Project Name	Activities	Original Cost	Cumulative Allocation	Amount Allocated	Project Status
ADMINISTRATION AND RECURRENT EXPENDTURE						
1	Employees' Salaries	Payment of staff salaries for 7 staff	2,120,160.00		2,120,160.00	New
2	Staff Gratuity	Payment of staff gratuity for 7 staff	657,250.00		657,250.00	New
3	NSSF	Payment of NSSF employer deductions for 7 staff	16,800.00		16,800.00	New
4	Casual labour and Internship	Payment of staff Basic Wages	360,000.00		360,000.00	New
Goods and Services						
5	Electricity charges	Payment of Electricity charges	72,000.00		72,000.00	New
6	Water & sewerage charges	Payment of Water & sewerage charges	14,400.00		14,400.00	New
7	Telephone, Telex, Facsimile and Mobile Phone Service	Payment of Telephone expenses	120,000.00		120,000.00	New
8	Internet Connections	Payment of Internet Connections	60,000.00		60,000.00	New
9	Courier and Postal Services	Payment of Courier and Postal Services	250,000.00		250,000.00	New
10	Publishing and Printing Services	Payment of Publishing and Printing Services	300,000.00		300,000.00	New
11	Subscriptions to Newspapers, Magazines and Periodicals	Payment of Subscriptions to Newspapers, Magazines and Periodicals	43,200.00		43,200.00	New
12	Advertising, Awareness and Publicity Campaigns	Payment of Advertising, Awareness and Publicity Campaigns	250,000.00		250,000.00	New
13	Catering Services (receptions), Accommodation, Gifts, Food and Drinks	Payment of catering Services (receptions), Accommodation, Gifts, Food and Drinks	240,000.00		240,000.00	New
14	Supplies and Accessories for	Purchase of Supplies and	300,000.00		300,000.00	New

National Government
Constituency Development Fund
Homa Bay Town Constituency

Fund Account Manager
P.O. BOX 240 HOMA BAY, 40300
cd@homabaytown@ncdf.go.ke

	Computers and Printers	Accessories for Computers and Printers				
15	Sanitary and Cleaning Materials, Supplies and Services	Purchase of Sanitary and Cleaning Materials, Supplies and Services	55,000.00		55,000.00	New
Travelling and Accommodation						
16	Daily Subsistence Allowance	Payment of Daily Subsistence Allowance	635,000.00		635,000.00	New
17	Sundry Items (taxi)	Payment of sundry items (airport transfer, taxis, expenses)	40,000.00		40,000.00	New
18	Hire of Transport	Payment of Hire of Transport	846,920.00		846,920.00	New
19	Refined Fuels and Lubricants	Purchase of Refined Fuels and Lubricants	300,000.00		300,000.00	New
NG-CDF Committee Expenses						
20	Committee Expenses	Payment of committee sitting allowances, transport, conferences	1,128,000.00		1,128,000.00	New
21	Other committee expenses	Payment of other committee expenses	406,322.31		406,322.31	New
MONITORING, EVALUATION AND CAPACITY BUILDING						
22	Travel Costs	Payment of Transport Expenses	650,000.00		650,000.00	New
23	Daily Subsistence Allowance	Payment of Daily Subsistence Allowance	366,000.00		366,000.00	New
24	Publishing and Printing Services	Payment of Publishing and Printing Services	160,000.00		160,000.00	New
25	Hire of Transport	Payment of Hire of Transport	300,000.00		300,000.00	New
26	Travel Allowance on training	Payment of Travel Allowance of NG-CDFC, National Government officers and PMC (project management, procurement and cross cutting issues)	500,000.00		500,000.00	New

National Government
Constituency Development Fund
Homa Bay Town Constituency

03 JAN 2023

Fund Account Manager

P.O. BOX 240 HOMA BAY, 40300
cedh@homa-baytown@ngcdf.go.ke

27	Remuneration of Instructors and Contract Based Training Services	Payment of Instructors and Contract Based Training Services NG-CDFC related issues and cross cutting issues)	160,000.00		160,000.00	New
28	Production and Printing of Training Materials	Payment of Production and Printing of Training Materials (project management, procurement and cross cutting issues)	96,000.00		96,000.00	New
28	Hire of Training Facilities and Equipment	Hire of Training Facilities and Equipment (project management, procurement and cross cutting issues)	254,400.99		254,400.99	New
30	Accommodation Allowance	Payment of Accommodation Allowance of NGCDFC, National Government officers and PMC (project management, procurement and cross cutting issues)	250,000.00		250,000.00	New
31	Catering Services (receptions), Accommodation, Gifts, Food and Drinks)	Payment of catering Services (receptions), Accommodation, Gifts, Food and Drinks	224,000.00		224,000.00	New
32	Other committee expenses	Payment of Other committee expenses	200,000.00		200,000.00	New
33	NGCDFC allowance	Payment of NG-CDFC allowances during M&E exercise	416,000.00		416,000.00	New
34	Purchase of Uniforms and Clothing - Staff	Purchase of branded NG-CDFC attires	150,000.00		150,000.00	New
35	General Office Supplies (papers, pencils, forms,	Purchase of General Office Supplies (papers, pencils, forms,	170,000.00		170,000.00	New



Handwritten signature

	small office equipment)	small office equipment)				
36	Refined Fuels and Lubricants for Transport	Purchase of Refined Fuels and Lubricants for Transport of GK vehicles	140,000.00		140,000.00	New
37	Maintenance Expenses - Motor Cycles	Payment of Maintenance Expenses - NG-CDFC - Motor Cycles	110,000.00		110,000.00	New
	NG-CDF OFFICE					
38	NG-CDF Office	Renovation of NG-CDF Office: modification of office to create 2 internal flush toilets (in the Fund Account Manager's Office and chairperson's office), plumbing works and guttering at Kshs.1,883,156.66 and purchase and installation of 10,000 litres water tank at Kshs.150,000	1,883,306.66		1,883,306.66	New
	STRATEGIC PLAN					
39	Homa Bay Town NG-CDF Strategic plan	To facilitate development of 5-year constituency strategic plan	2,000,000.00		2,000,000.00	New
	EMERGENCY					
40	Emergency	To cater for unforeseen occurrences in the Constituency during the Financial Year	7,636,190.00		7,636,190.00	New
	CONSTITUENCY OVERSIGHT COMMITTEE EXPENSES					
41	Travel Costs	Payment of the Constituency Oversight Committee Travel Costs (Airlines, Bus, Railway)	192,000		192,000	New

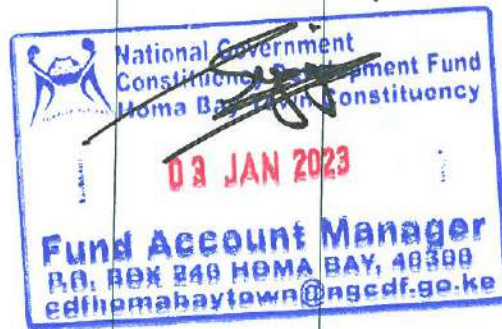

42	Accommodation - Domestic Travel	Payment of the Constituency Oversight Committee Domestic Travel accommodation expenses	240,000		240,000	New
43	Daily Subsistence Allowance	Payment of the Constituency Oversight Committee daily subsistence allowances	192,000		192,000	New
44	Constituency Oversight Committee Members Allowance	Payment of the Constituency Oversight Committee allowances	240,000		240,000	New
45	Refined Fuels and Lubricants for Transport	To cater for Refined Fuels and Lubricants for Transport during Constituency Oversight Committee activities	96,000		96,000	New
BURSARY						
46	Bursary – Secondary Schools	Bursary to cater for needy students in Secondary Schools	27,000,000.00		27,000,000.00	New
47	Bursary - Tertiary institutions (universities and Colleges)	Bursary funds to cater for needy students in tertiary Institutions.	8,000,000.00		8,000,000.00	New
48	Bursary - Special Schools	Bursary funds to cater for needy students in special Schools and Institutions.	700,000.00		700,000.00	New
SPORTS ACTIVITIES						
49	Constituency Sports Tournament	Organizing sport tournaments whereby the winning teams will be awarded with balls, nets, games kits and trophies	2,114,300.66		2,114,300.66	New
50	Regional Sports Tournament	facilitate regional sports tournament in partnership with other Constituencies within the	350,000.00		350,000.00	



		Region.				
ENVIRONMENT						
51	Otaro Primary School	Landscaping of 1.5 acres school compound (rough grades, drainage, hardscapes, Finish grades) to completion	914,300.00		914,300.00	New
PRIMARY SCHOOL						
52	Otaro Primary School	Fencing of 2.5 acres with concrete poles and six strands barbed wire complete with chainlink to completion	1,350,000		1,350,000.00	
53	Shauri Yako Primary School	Completion of a storey building of 4 Classrooms: Construction of the superstructure wall, reinforced concrete superstructure, Roofing, fittings of windows and doors complete with glazing and iron mongery, electrical installation, plastering, painting and tiling	7,841,295	4,000,000	3,841,295.00	Ongoing
54	Disii Primary School	Completion of administration block consisting of 3 offices and a staff room: Tiling and painting	3,025,850	2,501,000	524,850.00	Ongoing
55	Ogande Primary School	Completion of 3No. Classrooms: Fixing of fascia board and painting	3,208,900	3,000,000.00	208,900.00	Ongoing
56	Rodi Primary School	Completion of administration block consisting of 4 offices and a staff room: Tiling, painting, electrical works	3997860	3,500,000	497,860.00	Ongoing



		and project branding				
57	Ndori Primary School	Renovation of 2no. Classrooms (50 students per classroom) to completion: Tiling and painting	200,000.00		200,000.00	New
58	Akele Primary School	Renovation of 2no. Classrooms (50 students per classroom): Tiling, painting and electrical installation	400,000.00		400,000.00	New
59	Maguti Primary School	Completion of 2no. Classrooms (50 students per classroom): Tiling and painting	2,309,560	1,800,000	509,960.00	Ongoing
60	Kuja Primary School	Completion of 2No. Classrooms: Tiling, Glazing and Painting	2,086,900	1,500,000	586,900.00	Ongoing
61	Gogo Katuma Primary School	Completion of 2No. Classrooms (50 students per classroom): painting internally and externally	1,931,294	1,900,000	31,294.00	Ongoing
62	Yao Primary School	Completion of 2No. Classrooms (50 students per classroom): electrical installation and painting internally and externally	1,978,680	1,800,000	178,680.00	Ongoing
63	Magare Primary School	Completion of an administration block consisting of 2 offices and a staffroom: Roofing, fittings of windows and doors complete with glazing and iron mongery, plastering and painting and tilling to the floor and project	3,899,200	1,200,000.00	1,899,200.00	Ongoing



		branding				
64	Radiro Primary School	Completion of an administration block consisting of 3 offices and a staffroom: Roofing, fittings of windows and doors complete with glazing and iron mongery, plastering and painting and tilling to the floor and project branding	3,055,000	1,353,430.0 0	1,701,570.00	Ongoing
						
65	Pala Masogo Primary School	Completion of an administration block consisting of 2 offices and a staffroom: Roofing, fittings of windows and doors complete with glazing and iron mongery, plastering and painting and tilling to the floor and project branding	3,074,050	1,200,000.0 0	1,874,050.00	Ongoing
66	Sinangi Primary School	Completion of 2 No. Classrooms (50 students per classroom): glazing of the windows ,plastering and painting and tilling to the floor and project branding	2,251,690.00	1,600,000.0 0	651,690.00	Ongoing
67	Nyauu Primary School	Renovation to completion of 8no. Classrooms (50 students per classroom): Reroofing 2No. Classrooms, tiling, painting and glazing of	2,000,000.00		2,000,000.00	New

		8No. Classrooms to completion				
68	Nyakune Primary School	Renovation to completion of 3no. Classrooms (50 students per classroom): Plastering, painting, tiling and glazing to the three classrooms to completion	800,000.00		800,000.00	New
69	Nyanguu Primary School	Construction of administration block consisting of two offices and a staffroom to roofing level. <i>The project will be allocated Kshs.1,600,000 in 2023/24 financial year for completion</i>	3,500,000.00		1,900,000.00	new
70	Sinangi Primary School	Construction to completion of 4 door latrine (with 2 doors reserved for PWDs) to completion	800,000.00		800,000.00	New
71	Opande Primary School	Construction to completion of 2No. Classrooms (50 students per classroom)	2,000,000.00		2,000,000.00	New
72	Wiobiero Primary School	Renovation to completion of 5 No. classrooms (50 students per classroom): Reroofing of 3 No. Classrooms, construction of the verandah area, tiling, painting and glazing to 5 No. Classrooms	1,400,000.00		1,400,000.00	New



73	Ndiru Primary School	Completion of administration block consisting of a staffroom and 4 offices (Painting of the walls internally and externally and tiling) at kshs.1,100,000 and Renovation of 2No. Classrooms to completion (tiling, plastering and painting) at Kshs.400,000	4,356,400	2,856,400	1,500,000.00	Ongoing/new
74	Roba Primary School	Construction to completion of 2 No. Classrooms (50 students per classroom)	2,000,000.00		2,000,000.00	New
75	Sinangi Primary School	Construction to completion of 2No. Classrooms (50 students per classroom) <i>The school is located in swampy area hence need for reinforcement of foundation with a beam thereby the high cost of project</i>	2,239,233.38		2,239,233.38	New
76	Achiero Primary School	Construction to completion of 2 No classrooms at Kshs.2,279,017 and equipping with 50 desks at Kshs. 250,000; construction of a 4-door pit latrine (with 2 doors for PWDs) at Kshs. 790,083 and fencing of the school compound 3 acres with concrete poles and six strands of barbed wire and chain link at Kshs. 1,480,900	4,800,000.00		4,800,000.00	New
SECONDARY SCHOOLS						



77	Bishop Okulu Magare Girls school	Completion of 2 classrooms (50 students per classroom): Plastering and painting	1,800,000	1,500,000.00	300,000.00	Ongoing
78	Wiobiero Secondary School	Completion of a Laboratory of 45 students' capacity: painting and gas installation	4,500,000	4,000,000	500,000.00	Ongoing
79	Chiga Mixed Secondary School	Completion of 200 students' capacity library: Glazing of the windows, Plastering and painting of the walls and project branding	4,900,000	4,000,000	900,000.00	Ongoing
80	St. Camillus Ojunge Mixed Sec School	Completion of 60 students' capacity Laboratory: General laboratory fittings, fittings of windows and doors, painting and project branding.	5,000,000	4,000,000.00	1,000,000.00	Ongoing
81	St Dominic Wiga Mixed Secondary School	Completion of 2 No. Classrooms(50 students per classroom): plastering, Fittings of windows and doors complete with glazing, painting ,floor screed with smooth finish and project branding	1,950,000.00	1,700,000.00	250,000.00	Ongoing
82	Ogande Girls High School <i>The balance of Kshs.10 million shall be catered for in 2023/24 financial year. The Committee is also waiting</i>	Additional funds for construction of modern library (Dr. Ida Odinga Library Research Innovation and Resource Centre); fittings, fixtures and finishes of the library wing and reinforced concrete	50,000,000.00	30,000,000.00	10,000,000.00	Ongoing



	for disbursement of previous financial years' funds amounting to Kshs.13 million from the Board for this particular project. The committee therefore deemed it fit to allocate Kshs.10 million to the project so that the cumulative of the Kshs.23 million be used in this financial year (funds pending release inclusive).	superstructure of the entrance canopy, finishes of the flat roof and finishes of the columns with marine board				
83	St.Marys Marindi Girls Secondary School	Purchase of 51-seater school bus (Isuzu FRR 33L, 51-Seater semi luxury institution bus with diesel propelled engine	8,700,000.00	0.00	8,700,000.00	New
84	St Pius Ndiru Secondary School	Completion of 60 students' capacity laboratory; Fittings of windows and doors and plastering of the walls, Tiling of the floor, electrical installation and laboratory fittings.	5,000,000.00	3,500,000.00	1,500,000.00	Ongoing
85	St, Therasas Nyauu Girls Secondary School	Construction of a 50 students capacity dormitory to completion	3,500,000.00		3,500,000.00	New
86	Nyakahia Mixed Secondary School	Construction of 50 students' capacity Library: Substructure works, Reinforced	4,800,000.00		3,000,000.00	New



		Concrete Superstructure, Walling, roofing, fittings of windows and doors <i>The project will be allocated Kshs.1,800,000 in 2023/2024 financial year</i>				
87	Got Kokech Mixed Secondary School	Construction to completion of 2No. Classrooms	2,000,000.00		2,000,000.00	New
88	St Peters Disii Mixed Secondary School	Construction to completion of 4 No. Classrooms (using terrazzo floor) The school is located in an area with poor topography hence the high cost of project	5,000,000.00		5,000,000.00	New
SECURITY PROJECTS						
89	East Kanyada Location Chiefs Office	Completion of chiefs office consisting of 2 offices, conference and waiting bay: Superstructure works, roofing, fittings and plastering, painting, electrical works and project branding.	1,950,000.00	700,000.00	1,250,000.00	Ongoing
90	Kanyach Kachar Location Chiefs Office	Completion of chief's office consisting of 2 offices, conference and waiting bay Superstructure works, roofing, fittings and plastering, painting, electrical works and project branding	1,950,000.00	700,000.00	1,250,000.00	Ongoing



91	Komollo Location Chiefs Office	Completion of chief's office consisting of 2 offices, conference and waiting bay: Superstructure works, roofing, fittings and plastering, painting, electrical works and project branding	1,950,000.00	700,000.00	1,250,000.00	Ongoing
Total					138,215,033.00	



MIN.HBTC NG-CDFC 08/1/1/2022/2023: JUSTIFICATION FOR ALLOCATION OF FUNDS TO KEY STATUTORY VOTE HEADS

The Fund Account Manager informed the members that as per the Board's circular on preparation and submission of project proposals for 2022/23 FY, there is need to provide justification for allocation of funds to some statutory votes such as administration and recurrent expenditure, monitoring and evaluation, COC and strategic plan among others. The committee therefore resolved to provide the breakdowns as below: -

i. ADMINISTRATION AND RECURRENT EXPENITURE

a. Employees' Salaries and Gratuity

The Committee will engage the following staff on contractual basis during the year hence the justification for allocation of funds to staff salaries and gratuity. The basic salary for the staff indicated herein **is inclusive of their house allowances** in line with Section 31(2) (a) of the Employment Act 2007.

S/no	Position	Scale	Salary per Month	Salary per year	Gratuity per Month	Gratuity per Year	NSSF (Employer contribution per year)	Responsibility
1.	Accounts Assistant	CSG 11	32,170.00	386,040	9,973	119,672	2,400	Responsible for preparation of budget for office operation, maintenance and updatin of all books of account an PMC financial returns.
2.	Clerk of works	CSG 11	32,170.00	386,040	9,973	119,672	2,400	Responsible for routine monitoring of projects an maintenance of projects database
3.	Records management officer	CSG 14	18,890.00	226,680	5,856	70,271	2,400	Responsible for maintaining and updating all NG-CDF Committee ar PMC Records
4.	Project Coordinator	CSG 13	23,500.00	282,000	7,285	87,420	2,400	Responsible for assisting the Clerk of Works in the routine monitoring of projects and analysis of projects data.
5.	Procurement Assistant	CSG 11	32,170.00	386,040	9,973	119,672	2,400	Responsible for drafting o procurement plans and al

								other statutory reports related to procurement for submission to the PPRA
6.	Grounds man	CSG 14	18,890.00	226,680	5,856	70,271	2,400	Responsible for maintaining the general cleanliness of the NG-CD Office including the compound.
7.	Office Assistant	CSG 14	18,890.00	226,680	5,856	70,271	2,400	Responsible for all clerical tasks and any other duty assigned by the Fund Account Manager
	Total		176,680	2,120,160	54,772	657,250	16,800	

The committee also agreed to engage three interns during the year to be paid at a rate of Kshs.20,000 per month in line with the Public Service Commission Circular Ref. PSC/ADM/14 V (108) dated 16th December, 2016 on approved stipend and subsistence allowance for interns in the public service. The committee also resolved to allocate a lumpsum of Kshs.180,000 for hiring of casual employees on **NEED BASIS** without contravening the provision of Employment Act 2007 and all other labor laws.

Casual Labour and Internship	Number	Rate Per Month	Total pm	Total Pa.
Interns	3	20,000	60,000	180,000
Casual employees				180,000
Total				360,000

b. Travelling and Accommodation

Items	No. of persons	No. of days	Rate	Amount
Daily Subsistence Allowance				
Daily Subsistence allowance for members	8	8	5,000	320,000
Daily Subsistence allowance for chairperson	1	15	7,000	105,000
Daily Subsistence allowance for FAM	1	15	14,000	210,000
				635,000
Sundry Items (taxis)				40,000
Hire of Transport				846,920
Refined Fuels and Lubricants				300,000
Total				1,821,920

***Number of days for FAM and chairperson was agreed to be higher than the rest since they will have to make several follow ups on different issues relating to operations of the NG-CDFC including attending meetings convened by the Board and regional office

***The Committee undertakes to allocate funds for motor vehicle in the next financial year

c. NG-CDF Committee Expenses

The committee also resolved that they intend to hold 24 meetings during the financial year including meetings for sub-committees. It was therefore agreed that Kshs.1,128,000 be allocated for committee sitting allowances and Kshs.406,322.31 for any other expenses that will be incurred during the meetings include cost of water.

Items	No. of persons	No Meetings	Rate	Amount

Daily Subsistence allowance for members	8	24	5,000	960,000
Daily Subsistence allowance for chairperson	1	24	7,000	168,000
				1,128,000
Other Committee Expenses				406,322.31
Total				1,534,322.31

ii. MONITORING, EVALUATION AND CAPACITY BUILDING

Items	No. of persons	Number of days	Rate	Amount
NG-CDFC allowances during M&E				
Allowance for chairperson	1	8	7,000	56,000
Allowance for members	9	8	5,000	360,000
PMC trainings				
Payment of travel costs during PMC trainings	130	2	2,500	650,000
NGCDFC, Staff and National Government officers Trainings				
Daily Subsistence	1	6	7,000	42,000
Daily Subsistence allowance for FAM	1	6	14,000	84,000
Daily Subsistence allowance for members	8	6	5,000	240,000
Accommodation Allowance for National Government Officers	5	2	10,000	100,000
Accommodation Allowance for staff	5	6	5,000	150,000
Travel Allowances	100	2	2,500	500,000
Remuneration of Instructors and Contract Based Training Services	5	2	16,000	160,000
Publishing and Printing Services				160,000
Hire of transport during NG-CDFC and staff training				300,000
Production and Printing of Training Materials				96,000
Hire of Training Facilities and Equipment				254,400.99
Catering Services (receptions), Accommodation, Gifts, Food and Drinks				224,000
Purchase of branded NG-CDF attires				150,000
General Office Supplies (papers, pencils, forms, small office equipment)				170,000
Fuel				140,000
Maintenance Expenses for NG-CDFC - Motor Cycles				110,000
Other committee expenses				200,000
				4,146,400.99

National Government
 Constituency Development Fund
 Homabay Town Constituency
 03 JAN 2023
 Fund Account Manager
 P.O. BOX 249 HOMABAY, 40300
 cdthomabaytown@ncdf.go.ke

iii. CONSTITUENCY OVERSIGHT COMMITTEE

Description	Number	Rate	No. of days	Total Amount
Domestic Travel and Subsistence & Other Transport Costs				
Travel Costs (Airlines, Bus, Railway, Mileage Allowances)	4	4,000	12	192,000
Accommodation - Domestic Travel	4	5,000	12	240,000
Daily Subsistence Allowance	4	4,000	12	192,000
COC Members Allowance	4	5,000	12	240,000
Refined Fuels and Lubricants for Transport				96,000
Total				960,000

[Handwritten signature]

[Handwritten signature]

iv. STRATEGIC PLAN

NO.	ITEM	NO. OF PAX	NO OF WARDS/FREQ	RATE (KSHS)	TOTAL
1	Refreshments and Facilitation for Stakeholders consultations	50	4	500	100,000
2	Technical and support team Facilitation & Logistics				100,000
3	Consultancy Fee				1,400,000
4	Refreshments and Facilitation Stakeholders Validation Forums	30	4	1000	120,000
5	Fact Sheet Data Collection				30,000
6	Printing of Final Document				100,000
7	Launching				150,000
	TOTAL				2,000,000

MIN.HBTC NG-CDFC 09/01/1/2022/2023: AOB

There being no any other business, the meeting ended by a word of prayer from Mr. John Onyango at 1308 hrs. The date for the next meeting will be communicated by the Chairperson through the secretary.

Signed by;

Chairperson:  Date: 03/01/2023

Secretary:  Date: 03/01/2023





Homa Bay Town

IEBC Number 249

National Government Constituency Development Fund

WARD MEETINGS REPORT

2022/2023 Financial Year

Submitted

JANUARY 2023

Table of Contents

INTRODUCTION23

WHY PUBLIC PARTICIPATION?23

About NGCDF23

Eligible Projects Fundable by Homabay Town NG-CDF24

The ineligible projects include:24

BACKGROUND INFORMATION OF HOMA BAY TOWN CONSTITUENCY24

THE GEOGRAPHY25

ADMINISTRATIVE AND POLITICAL UNITS25

Homabay Town Constituency Geographical Map26

NOTICE OF THE MEETINGS27

DAY ONE: HOMABAY EAST WARD28

Members Present28

Preliminaries28

Comments by the Area Assistant Chief28

Comments by the Secretary of NG-CDFC28

Comments by the Chairperson of NG-CDFC28

Project Priorities Identified In the Ward28

Comments by the Area Member of National Assembly29

Photos30

DAY TWO: HOMABAY WEST WARD30

Members Present30

Preliminaries30

Comments by the Area Chief30

Comments by the Fund Account Manager30

Comments by the Chairperson of NG-CDFC31

Project Priorities Identified In the Ward31

Closing Remarks by the Chairperson of NG-COC31

Photos31

DAY THREE: HOMABAY ARUJO WARD32

Members Present32

Preliminaries32

Comments by the Deputy County Commissioner32

Comments by the NG-CDFC Chairperson32

Project priorities identified in Arujo Ward32

Challenges33

Photos33

DAY FOUR: HOMABAY CENTRAL WARD33

Members Present33

Preliminaries33

Comments by the NG-CDFC Chairperson33

Comments by the NG-CDFC Secretary34

DEPUTY COUNTY COMMISSIONER
HOMABAY SUB-COUNTY

DEPUTY COUNTY COMMISSIONER
HOMABAY SUB-COUNTY

[Handwritten Signature]

National Government
Constituency Development Fund
Homa Bay Town Constituency

03 JAN 2023

Fund Account Manager
P.O. BOX 240 HOMA BAY, 40300
cdfhomabaytown@ngcdf.ga.ke

Project Priorities Identified In the Ward34

Challenges.....34

Way Forward34

Closing Remarks by the Area Member to the National Assembly.....34

Photos..... Error! Bookmark not defined.

1. INTRODUCTION

The National Government Constituencies Development Act 2015 stipulates in section 27 (1) that the Chairperson of the Constituency Committee shall, within the first year of the commencement of a new Parliament and at least once every two years thereafter, convene open forum public meetings in every ward in the constituency to deliberate on development matters in the ward and in the constituency.

1. WHY PUBLIC PARTICIPATION?

Public participation is a constitutional requirement specifically; Article 1 that states that sovereign power belongs to the people. Public participation is a structured way of consulting with persons, groups and entities before decisions are made. It is designed to give a voice to the voiceless and cements the concept of agency by the Government, that is, the government becomes an agent of the people.

Public participation is not meant to convey decisions already made, but to generate and confirm decisions. It is not a political process but a non-partisan process that involves the agent going to 'take instruction and direction' from the people.

Public participation is having an open, accountable and structured process where citizens or people or segment of a community can interact, exchange views and influence decision making. It is critical that all stakeholders are involved in the development of projects and not just direct beneficiaries of an initiative.

Homabay Town NG CDF committee in compliance with the law gave out notices and followed by having public participation forums in all the four wards in the constituency as from 27th December, 2022 to 30th December, 2022.

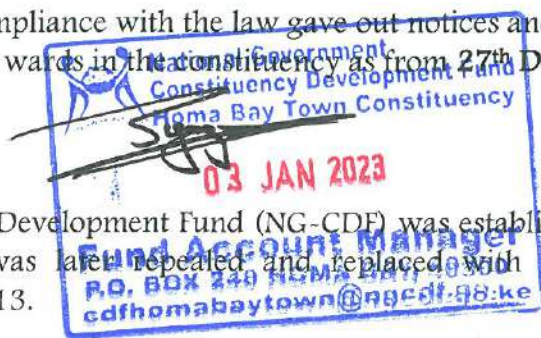

2. About NGCDF

The National Government Constituencies Development Fund (NG-CDF) was established by the Constituencies Development Fund Act, 2003, which was later repealed and replaced with the National Government Constituencies Development Fund Act, 2013.

This NGCDF Act 2015 (Amended 2016) came into force in February of 2016, after the now repealed CDF Act, 2013 which was declared unconstitutional on 17th February, 2015, but the unconstitutionality was deferred for one year to give the legislature time to amend or pass a new law as well as for the purposes of the transition as there were still contracts being executed.

The primary objective of the Fund is to reduce poverty by dedicating a minimum of 2.5% of the national government ordinary revenue to all constituencies in Kenya to promote infrastructural development and socio-economic growth.

Specifically, the mandate of the Fund as derived from sec (3) of NG-CDF Act, 2015 is to:

- a) Recognize the constituency as a platform for identification, performance and implementation of national government functions;
- b) Facilitate the performance and implementation of national government functions in all parts of the Republic pursuant to Article 6(3) of the Constitution;

(Handwritten signatures and stamps)

DEPUTY COUNTY COMMISSIONER
HOMABAY SUB-COUNTY

- c) Provide for the participation of the people in the determination and implementation of identified national government development projects at the constituency level pursuant to Article 10(2)(a) of the Constitution;
- d) Promote the national values of human dignity, equity, social justice, inclusiveness, equality, human rights, non-discrimination and protection of the marginalized pursuant to Article 10 (2) (b) of the Constitution;
- e) Provide for the sustainable development of all parts of the Republic pursuant to Article 10 (2) (d) of the Constitution;
- f) Provide a legislative and policy framework pursuant to Article 21 (2) of the Constitution for the progressive realization of the economic and social rights guaranteed under Article 43 of the Constitution;
- g) Provide mechanisms for the National Assembly to deliberate on and resolve issues of concern to the people as provided for under Article 95 (2) of the Constitution;
- h) provide for a public finance system that promotes an equitable society and in particular expenditure that promotes equitable development of the country by making special provisions for marginalized groups and areas pursuant to Article 201 (b) (iii) of the Constitution;
- i) Authorize withdrawal of money from the Consolidated Fund as provided ' under Article 206 (2) (c) of the Constitution;
- j) Provide mechanisms for the National Assembly to facilitate the involvement of the people in the identification and implementation of projects for funding by the national government at the constituency level; and
- k) Provide for mechanisms for supplementing infrastructure development at the constituency level in matters falling within the functions of the national government at that level in accordance with the Constitution

1. Eligible Projects Fundable by Homabay Town NG-CDF

The eligible projects fundable by NG-CDF as stipulated in section 24 of the NG-CDF (amendment) Act, 2016 as those that are in:

- Respect of works and services falling within the functions of the National Government under the constitution
- Must be community based to ensure that the prospective benefits are available to a widespread cross-section of the inhabitants of a particular area.

2. The ineligible projects include:

- Projects supporting religious bodies or religious activities
- Projects supporting political bodies or political activities
- Recurrent costs of completed projects
- Personal awards
- Projects targeting a specific club or group of people to the exclusion of others
- Projects addressing devolved functions as outlined in the fourth schedule of the constitution of Kenya



2. BACKGROUND INFORMATION OF HOMA BAY TOWN CONSTITUENCY

Homa Bay Town Constituency was established following electoral boundary delimitation in the year 2012. It is one of the eight (8) constituencies constituting Homa Bay County. The Constituency hosts the headquarters of Homa Bay County. The other seven constituencies in Homa Bay County are: Suba South, Suba North, Ndhiwa, Rangwe, Karachuonyo, Kasipul and Kabondo-Kasipul constituencies.

The Member of Parliament for this constituency, since its establishment is Honorable George Peter Opondo Kaluma.

[Handwritten signature]
 HOMA BAY COUNTY COMMISSIONER
 HOMA BAY SUB-COUNTY

[Handwritten signature]

1. THE GEOGRAPHY

It is located 105km South West of Kisumu City and 405km North West of Nairobi the capital city of Kenya.

2. ADMINISTRATIVE AND POLITICAL UNITS

The constituency has a population of approximately 97,500 according to the Kenya Population and Housing Census 2019. It is divided into nine (9) locations and fourteen (14) sub location. The administrative units are as shown in table 1 below:

S/N	LOCATION	SUB-LOCATION
1.	Komollo	Komollo
2.	Kothidha	Kothidha
3.	Kanyach/Kachar	Kanyach/Kachar
4.	East Kanyada	Kubuola/Kagwang'
5.	Kanyango/Kalanya	Kanyango/Kalanya
6.	Homa Bay Town	<ul style="list-style-type: none"> • Homa Bay Township • Asego
7.	Arujo	Arujo
8.	West	<ul style="list-style-type: none"> • Kotieno • Katuma
9.	Kanyabala	<ul style="list-style-type: none"> • Kanyabala North • Kanyabala Southn

The constituency is divided into four (4) county assembly wards as outlined in the table below:

S/N	WARD	WARD NO.	AREA(KM2)
1.	Homa Bay Central Ward	1241	25.90
2.	Homa Bay Arujo Ward	1242	13.30
3.	Homa Bay West Ward	1243	90.20
4.	Homa Bay East Ward	1244	69.20





NATIONAL GOVERNMENT CONSTITUENCIES DEVELOPMENT FUND
HOMABAY TOWN CONSTITUENCY
 Kabunde Multipurpose Hall
 P.O BOX 240 Homabay, 40300
 Email: cdfhomabaytown@ngcdf.go.ke | Website: www.ngcdf.go.ke

NG-CDF BOARD

Our Ref: HBTC/NG-CDF/P.PARTICIPATION/01/2022/2023

21ST DECEMBER, 2022

3. NOTICE OF THE MEETINGS

HOMABAY TOWN NG-CDF INVITES ALL ITS CONSTITUENTS AND DEVELOPMENT STAKEHOLDERS TO THE NG-CDF PUBLIC PARTICIPATION FOR PURPOSES OF PROJECTS IDENTIFICATION, PREPARATION AND SUBMISSION OF PROPOSALS.

THE ACTIVITY IS SCHEDULED ACROSS ALL THE FOUR WARDS AS UNDER:

DATE/DAY	VENUE	WARD	TIME (EAT)
Tuesday 27 th December, 2022	Ndiru Primary School	East Ward	9.00 am
Wednesday 28 th December, 2022	Olodo Chief's Camp	West Ward	9.00 am
Thursday 29 th December, 2022	Kabunde Multipurpose Hall	Arujo Ward	9.00 am
Friday 30 th December, 2022	Muche Primary School	Central Ward	9.00 am

KINDLY MOBILIZE PEOPLE FROM YOUR AREAS OF REPRESENTATION AND WARD DEVELOPMENT COMMITTEE SHOULD COME UP WITH A PRIORITY LIST OF PROJECTS THAT THEY WOULD HOMABAY TOWN NG-CDF TO UNDERTAKE IN THE NEXT TWO FINANCIAL YEARS.

ALL ARE WELCOME.

Signed,

WILSON OKUMU OGOGO
FUND ACCOUNT MANAGER
 +254-722-700-485



4. DAY ONE: HOMABAY EAST WARD

The meeting took place on Tuesday 27th December, 2022 at Ndiru Primary School as from 10:00am.

5. Members Present

- ❖ NG-CDF Committee Members
- ❖ NG-CDF Staff
- ❖ Constituency Oversight Committee Members
- ❖ Area Chiefs
- ❖ Secondary Schools Heads Representative
- ❖ Primary Schools Heads Representative
- ❖ Members of the Public



6. Preliminaries

7. Comments by the Area Assistant Chief

The area assistant chief welcomed members to the meeting after an opening prayer on behalf of his senior (the area chief) who was committed on other official duties, she thanked the NG-CDFC team, Member of Parliament and Constituency Oversight Committee Members for presenting the constituents with an opportunity of identifying projects to be funded by NG-CDF, for this was going to promote ownership of the projects before, during and after implementation. The Assistant Chief told members that NG-CDF had proved to be the only entity whose projects can be singled as having been fully implemented and help the entire community and urged the Members of Parliament to continue with the good work in order to reach all ends of the community.

8. Comments by the Secretary of NG-CDFC.

The Secretary was impressed by the turnout of members after such a short notice of invitation. He appreciated the members for honoring the invitation to be part of the exercise.

9. Comments by the Chairperson of NG-CDFC

The Chairman thanked the constituents for attending the meeting, he explained the relevance of the meeting and the need for NG-CDFC to convene open forum public meetings at in every ward in the constituency to deliberate on development matters and project priorities in the ward and the constituency. The Chairperson further explained to the general public the relevance of the forum as stipulated in the NG-CDF ACT 2015, and the nature of projects fundable by NG-CDF to include projects that are communal and benefit a wide cross section of the inhabitants, leaving out project that benefit individuals, supporting political and religious bodies and those that are in respect of works and services falling within the devolved functions of the County Government.

10. Project Priorities Identified In the Ward

Below is a summary of proposal request for the East ward as highlighted by various participants

NO	SCHOOL	SECTOR	ACTIVITY
15.	Disii Primary School	Education	Completion of administration block
16.	Ogande Primary School	Education	Completion of 3No. Classrooms



17.	Ndori Primary School	Education	Completion of 2no. Classrooms
18.	Nyanguu Primary School		Construction of administration block consisting of two offices
19.	Sinangi Primary School	Education	<ul style="list-style-type: none"> • Completion of 2 No. Classrooms • Construction of 4 door latrine • Construction and equipping of 2No. Classrooms
20.	Nyauu Primary School	Education	Renovation of 8no. Classrooms
21.	Ndiru Primary School	Education	Renovation of administration block and 2No. Classrooms
22.	Roba Primary School	Education	Construction of 2 No. Classrooms
23.	Achiero Primary School	Education	Construction and equipping of 2 No classrooms
24.	Pala Masogo Primary School	Education	Construction of an administration block consisting of 2 offices
25.	Chiga Mixed Secondary School	Education	Completion of a library block
26.	Ogande Girls High School	Education	Construction of Modern Library (Dr. Ida Odinga Library, innovation and Resource Centre
27.	St Pius Ndiru Secondary School	Education	Construction of a Laboratory
28.	St. Theresa's Nyauu Girls Secondary School	Education	Construction of a dormitory
29.	St. Peters Disii Mixed Secondary School	Education	Construction of 4 No. Classrooms
30.	St.Marys Marindi Girls Secondary School		Purchase of 51 seater school bus
31.	Otaro Primary School	Environment	Landscaping and fencing of the school compound
32.	East Kanyada Location Chiefs Office	Security	Construction of chiefs office
33.	Kanyach Kachar Location Chiefs Office	Security	Construction of chiefs office
34.	Komollo Location Chiefs Office	Security	Construction of chiefs office

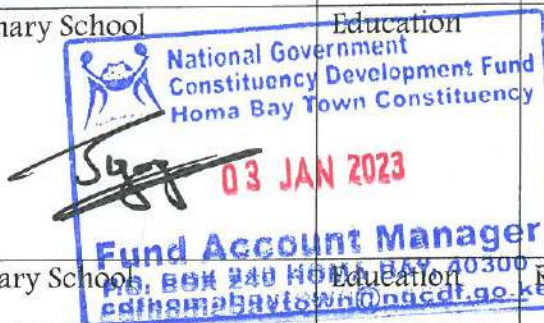

11. Comments by the Area Member of National Assembly

The area Member of National Assembly, Hon Peter Opondo Kaluma thanked the residents of Homabay East Ward for showing up in large numbers and voting him in as their preferred candidate for three terms in a row. He emphasised on his ability to deliver to the constituents the much he promised them during the campaigns. He further encouraged them to prioritise their wants for easy planning.

After a lengthy chat with members present, *Mheshimiwa* thanked everyone who showed up for that crucial activity and assured them that the NG-CDF committee in conjunction with the Constituency oversight committee, guided by with their requests, will deliberate on the project proposal and prioritize them on the need basis. He further assured the public that once the project proposal is complete, the NG-CDF team will present a copy of the same to the area chief so that it can be accessed by the members of the members' public.

Handwritten signatures and a blue stamp. The stamp reads 'DEPUTY COMMISSIONER HOMA BAY SUB-COUNTY'.

1. Photos



12. DAY TWO: HOMABAY WEST WARD

The meeting took place on Wednesday 28th December, 2022 at Olodo Chief's Camp as from 10:00am.

13. Members Present

- 1) NG-CDF Committee Members
- 2) Constituency Oversight Committee Members
- 3) Area Chiefs
- 4) Secondary Schools Heads Representative
- 5) Primary Schools Heads Representative
- 6) Members of the Public

14. Preliminaries

15. Comments by the Area Chief

The area chief welcomed called the meeting to order and requested a volunteer to lead the members in an opening prayer. He welcomed all the participants to Olodo Chiefs Camp and urged the general public to actively participate in the forum as it will greatly impact them once their proposals have been implemented. He further thanked the management of Homabay Town NG-CDF for organizing the forum where the public have the opportunity to front the projects that they would like to be implemented within the framework of NG-CDF.

16. Comments by the Fund Account Manager

He informed the meeting on the nature of eligible projects fundable by NG-CDF as community based to ensure that the prospective benefits are available to a widespread cross-section of the inhabitants of a particular area and those in respect of works and services falling within the functions of the National Government under the constitution.

Further to this, He also highlighted the ineligible projects which include: Projects supporting religious bodies or religious activities, projects supporting political bodies or political activities, recurrent costs of a completed projects, personal projects, private projects and projects targeting a specific club or group of people to the exclusion of others. He encouraged members to make proposals within the mandate of NG-CDF.



17. Comments by the Chairperson of NG-CDFC.

The Chairman encouraged the members present to reach out to their neighbors who had not shown up for the meeting to come as the turnout of the residents of Homabay West Ward was very low. He stressed on the NG-CDF committees commitment on sensitizing the public on bursary applications and focus on development issues. He further informed the members that all the projects cannot be implemented at once but gradually hence the need of setting priorities. The law requires that ongoing projects be given first priority in funding before starting new ones.

National Service Constituency Development Fund
Homa Bay Town Constituency
03 JAN 2023
Fund Account Manager
P.O. BOX 240 HOMA BAY, 40300
rdm@hombaytown@ngcdf.go.ke

18. Project Priorities Identified In the Ward

The summary of project for the ward as highlighted in the venue is listed as under:

NO	SCHOOL	SECTOR	ACTIVITY
1.	Akele Primary School	Education	Construction of 2no. Classrooms
2.	Maguti Primary School	Education	Construction of 2no. Classrooms
3.	Magare Primary School	Education	Construction of an administration block consisting of 2 offices
4.	Radiro Primary School	Education	Construction of an administration block consisting of 2 offices
5.	Nyakune Primary School	Education	Renovation of 3no. Classrooms
6.	Bishop Okulu Magare Girls school	Education	Construction of 2 new classrooms
7.	Nyakahia Mixed Secondary School	Education	Construction of library Construction Of 60 students capacity science laboratory:

19. Closing Remarks by the Chairperson of NG-COC.

Mr. Leonard Owuor, representing the Constituency Oversight informed members of Honorable Kalumas commitment to Homa bay Town Constituency where he mentioned that the Member of Parliament in collaboration with NG-CDFC had ensured a wide spread and even distribution of projects across all the wards in the Constituency. He thanked the area Chiefs and Assistant Chiefs Present for their commitment to attend the meeting and their commitment to serve the *wananchi* of Homabay Town Constituency.

20. Photos



[Handwritten signatures]
Page 31 of 35
DEPUTY CHIEF OF POLICE
HOMABAY SUB-COUNTY

21. DAY THREE: HOMABAY ARUJO WARD

The meeting took place on Thursday 29th December, 2022 at Kabunde Multipurpose Hall at 10:00 AM

22. Members Present

- ❖ NG-CDF Committee Members
- ❖ Area Chiefs and Assistant Chiefs
- ❖ Secondary Schools Heads Representatives
- ❖ Primary Schools Heads Representatives
- ❖ Members of the public
- ❖ Constituency Oversight Committee Members



23. Preliminaries

The area chief welcomed members to the meeting after an opening prayer, he thanked the NG-CDFC and Member of Parliament for presenting the constituents with an opportunity of identifying projects for implementation by the NG-CDF.

24. Comments by the Deputy County Commissioner

The DCC commended the area MP and the management of the NG-CDFC for their excellent work in ensuring the constituents of Homabay Town Constituency gets nothing but the best, always. He went ahead to applaud the participants for their attendance and appealed the meeting to encourage all development stakeholders to have a positive attitude and dedication towards development, since development cannot be initiated and owned by foreigners but by the residents themselves.

Mr. Wasonga further mentioned how much the fund had impacted the livelihoods of the constituents as there are several needy cases he'd referred to the NG-CDF offices for bursary assistance whom had been successfully sponsored through secondary schools into the tertiary institutions.

He pleaded with the NG-CDFC to consider funding to completion all the ongoing projects in the constituency so that they could benefit the constituents as had been earlier intended.

As he concluded, the DCC informed the participants that NG-CDF has proved to be the only entity whose projects can be singled as having been fully implemented, audited and help the entire community and urged the Members of Parliament to continue with the good work in order to reach all ends of the community and the technical teams to ensure that the those projects are properly branded.

25. Comments by the NG-CDFC Chairperson

The chairman thanked the residents of Arujo Ward for attending the meeting, he explained the relevance of the meeting and the need for NG-CDFC to convene open forum public meetings at in every ward in the constituency to deliberate on development matters and project priorities in the ward and the constituency. He encouraged the member of the public to be free to make their proposals.

26. Project priorities identified in Arujo Ward

The summary of project for the ward as highlighted in the venue is listed as under;

NO	SCHOOL	SECTOR	ACTIVITY
----	--------	--------	----------



1.	Shauri Yako Primary School	Education	Construction of 4 No. Classrooms storey building
2.	Opande Rarage Primary School	Education	Construction 2No. Classrooms

27. Challenges

Members expressed concern on the restrictive nature of the projects fundable by NG-CDF, especially in the agricultural, health and roads sectors, but the NG-CDF Chairperson urged them to forward the projects to the area member of county assembly who was also present in the meeting.

1. Photos



28. DAY FOUR: HOMABAY CENTRAL WARD

The meeting took place on Friday 30th December, 2022 at Muche Primary School starting from 10:00am.

29. Members Present

- 1) NG-CDF Committee
- 2) Constituency Oversight Committee Members
- 3) Area Chief
- 4) Secondary Schools Heads Representative
- 5) Primary Schools Heads Representative
- 6) Community members
- 7) Invited Stakeholders



30. Preliminaries

The area chief brought the meeting to order after which he requested a volunteer to lead the group in a word of prayer. He then requested the NG-CDFC Chairperson to take charge after welcoming all the members present.

31. Comments by the NG-CDFC Chairperson

The chairperson appreciated the members for their positive response towards the call to be part of the participation. He informed the members that the exercise that was ongoing is clearly stated in Section 27 of the NG-CDF Act 2015 amended 2016; that the chairperson of the constituency committee within the 1st year of the commencement of a new parliament and at least once at every two years thereafter convene open forum public meetings in every ward in the constituency to deliberate on development matters in the ward and in the constituency. He went ahead to encourage the members that they should free to outline all the pressing development issues from their areas of representation as this was the right forum.

32. Comments by the NG-CDFC Secretary

The NG-CDFC Secretary Mr. Charles Bugo emphasized that public participation is very essential in decision making by the NG-CDFC to enhance equitable distribution of resources across the wards depending on their needs and improve quality of service delivery.

33. Project Priorities Identified In the Ward

The identified projects were presented as follows:

NO	SCHOOL	SECTOR	ACTIVITY
1.	St Dominic Wiga Mixed Secondary School	Education	Completion of 2 No. Classrooms
2.	Wiobiero Secondary School	Education	Construction of a Laboratory
3.	St. Camillus Ojunge Mixed Sec School	Education	Construction of a Laboratory
4.	Wiobiero Primary School	Education	Renovation of 5 No. classrooms
5.	Kuja Primary School	Education	Construction of 2No. Classrooms to completion

34. Challenges

The NG-CDFC Chairperson explained to the members that the NG-CDF only funds bursary, education, environment, sports and security projects. However, the members had presented some proposals that were outside the NG-CDF docket and were advised to redirect them to the area members of national assembly as devolved projects like construction of health centers are being funded by the county governments.

35. Way Forward

The meeting resolved that all the funds disbursed to projects be spent judiciously to promote value for money and boost the livelihood of the residents.



36. Closing Remarks by the Area Member to the National Assembly

The Area Member of Parliament took the opportunity to thank all leaders especially the Members of public for taking their time and showing commitment towards developing Homabay Town Constituency. He urged the members of the public to cooperate with the NG-CDFCs so as to make the Constituency the best in terms of development in the County and Region.

He further enlightened the meeting of the various devolved funds in the constituency, and stressed the need of all the stakeholders to come together during planning to avoid duplication and double funding of projects. He called upon the County Government and KeRRA to share their development projects publicly to enable the constituents be aware of projects being implemented in their areas. He also mentioned about bursary program which was being offered by both Affirmative Action fund, Ward bursary by County Government, Children's Office and NG – CDF, a fund which if all parties shared their ideas will benefit a wide cross section of the constituent's needy cases in terms of School fees. He thanked members of the public for showing up during the meeting in honor of the invite and public notice so as to participate in project identification process as required by NG-CDF regulations and guidelines.

In conclusion, he requested the Constituency Chairperson to close the meeting with a word of prayer at 5:48pm after which members dispersed at their own pleasure.

03 JAN 2023
Fund Account Manager
P.O. BOX 240 HOMA BAY, 40300
homabaytown@ngcdf.go.ke

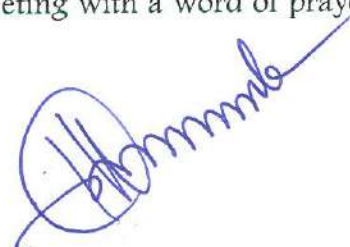

Page 34 of 35





Report compiled by *[Signature]*

**National Government
Constituency Development Fund
Homa Bay Town Constituency**
03 JAN 2023
FUND ACCOUNT MANAGER
Fund Account Manager
P.O. BOX 248 HOMA BAY, 40300
cdfhombaytown@ngcdfc.or.ke

[Signature]
**DEPUTY COUNTY
COMMISSIONER
HOMABAY SUB-COUNTY**

Confirmed by

[Signature]

NG-CDFC CHAIRPERSON

**THIRD SCHEDULE (ss. 25(6), (11) and 29(1))
CONSTITUENCY PROJECTS SUBMISSION FORM**

CONSTITUENCY NO. 249

CONSTITUENCY NAME: HOMA BAY TOWN

FINANCIAL YEAR: 2022-2023

SERIAL	NAME OF PROJECT	AMOUNT ALLOCATED (KSHS)
249/AP1	Administration/Recurrent	8,215,052.31
249/AP2	Monitoring and evaluation/Capacity Building	4,146,400.99
249/2640100	Bursary/Mocks/Cats	35,700,000.00
249/2640200	Emergency Projects	7,636,190.00
249/2630204	Primary School Projects	33,895,482.38
249/2630205	Secondary School Projects	36,650,000.00
249/2640507	Security Projects	3,750,000.00
249/2640509	Sports Activities	2,464,300.66
249/2640510	Environmental Projects	914,300.00
249/3110202	CDFC offices	1,883,306.66
249/2211310	Contracted Professional Services - e.g Strategic Planning	2,000,000.00
249/AP3	Constituency Oversight Committee	960,000.00
TOTAL		138,215,033.00

Harrison Ouko
[Signature]
Chairman

[Signature]
Signature

10 / 01 / 2023
Date

Wilson Oukun
[Signature]
Fund Manager

[Signature]
Signature

10 / 1 / 23
Date



FOURTH SCHEDULE (s. 30) PROJECT DESCRIPTION FORM

Constituency No 249

Constituency Name HOMA BAY TOWN County Homa Bay

Project Number AP1

Project Title Administration/Recurrent

Sector Administration & Recurrent

Status of projects

Brief statement on project status at time of submission

Financial year 2022-07-01 to 2023-07-31

Original Cost Estimates, in Ksh 8,215,052.31 dated

Amount allocated last financial year dated

Sub projects

Project Name	Project Code	Activity	Original Status	Amount (Ksh)
Employees Salaries	4-0043-249-2110000-100-2022-2023-1	Payment of staff salaries for 7 staff	New Project	2,120,160.00
Staff Gratuity	4-0043-249-2710102-100-2022-2023-2	Payment of staff gratuity for 7 staff	New Project	657,250.00
NSSF	4-0043-249-2120101-100-2022-2023-3	Payment of NSSF employer deductions for 7 staff	New Project	16,800.00
Casual labour and Internship	4-0043-249-2110202-100-2022-2023-4	Payment of staff Basic Wages	New Project	360,000.00
Electricity charges	4-0043-249-2210101-100-2022-2023-5	Payment of Electricity charges	New Project	72,000.00
Water & sewerage charges	4-0043-249-2210102-100-2022-2023-6	Payment of Water & sewerage charges	New Project	14,400.00
Telephone, Telex, Facsimile and Mobile Phone Service	4-0043-249-2210201-100-2022-2023-7	Payment of Telephone expenses	New Project	120,000.00
Internet Connections	4-0043-249-2210202-100-2022-2023-8	Payment of Internet Connections	New Project	60,000.00
Courier and Postal Services	4-0043-249-2210203-100-2022-2023-9	Payment of Courier and Postal Services	New Project	250,000.00
Publishing and Printing Services	4-0043-249-2210502-100-2022-2023-10	Payment of Publishing and Printing Services	New Project	300,000.00
Subscriptions to Newspapers,	4-0043-249-2210503-100-2022-2023-11	Payment of Subscriptions to Newspapers, Magazines and	New Project	43,200.00



03 JAN 2023
Fund Account Manager
 P.O. BOX 248 HOMA BAY, 40300
 cdfhomabaytown@ngcdt.go.ke

National Government Constituencies Development Fund
Fourth Schedule Report

Magazines and Periodicals		Periodicals		
Advertising, Awareness and Publicity Campaigns	4-0043-249-2210504-100-2022-2023-12	Payment of Advertising, Awareness and Publicity Campaigns	New Project	250,000.00
Catering Services (receptions), Accommodation, Gifts, Food and Drinks	4-0043-249-2210801-100-2022-2023-13	Payment of catering Services (receptions), Accommodation, Gifts, Food and Drinks	New Project	240,000.00
Supplies and Accessories for Computers and Printers	4-0043-249-2211102-100-2022-2023-14	Purchase of Supplies and Accessories for Computers and Printers	New Project	300,000.00
Sanitary and Cleaning Materials, Supplies and Services	4-0043-249-2211103-100-2022-2023-15	Purchase of Sanitary and Cleaning Materials, Supplies and Services	New Project	55,000.00
Daily Subsistence Allowance	4-0043-249-2210403-100-2022-2023-16	Payment of Daily Subsistence Allowance	New Project	635,000.00
Sundry Items (taxis)	4-0043-249-2210304-100-2022-2023-17	Payment of sundry items (airport transfer, taxis, expenses)	New Project	40,000.00
Hire of Transport	4-0043-249-2210604-100-2022-2023-18	Payment of Hire of Transport	New Project	846,920.00
Refined Fuels and Lubricants	4-0043-249-2211201-100-2022-2023-19	Purchase of Refined Fuels and Lubricants	New Project	300,000.00
Committee Expenses	4-0043-249-2210811-100-2022-2023-20	Payment of committee sitting allowances, transport, conferences	New Project	1,128,000.00
Other committee expenses	4-0043-249-2210802-100-2022-2023-21	Payment of other committee expenses	New Project	406,322.31
TOTAL:				8,215,052.31

Person completing form

SIGNATURE: _____

DATE: _____

NAME: _____

POSITION: _____

[Handwritten Signature]
Wilson Oduu
 10 / 1 / 23
FAM



**FOURTH SCHEDULE (s. 30)
PROJECT DESCRIPTION FORM**

Constituency No 249
 Constituency Name HOMA BAY TOWN County Homa Bay
 Project Number 2110000
 Project Title Employees salaries
 Sector Administration & Recurrent

Status of projects

Brief statement on project status at time of submission

Financial year 2022-07-01 to 2023-07-31
 Original Cost Estimates, in Ksh 2,120,160.00 dated
 Amount allocated last financial year dated

Sub projects

Project Name	Project Code	Activity	Original Status	Amount (Ksh)
Employees Salaries	4-0043-249-2110000-100-2022-2023-1	Payment of staff salaries for 7 staff	New Project	2,120,160.00
			TOTAL:	2,120,160.00

Person completing form

SIGNATURE:  DATE: 10 / 1 / 23
 NAME: Wilson Okumu POSITION: Farmer

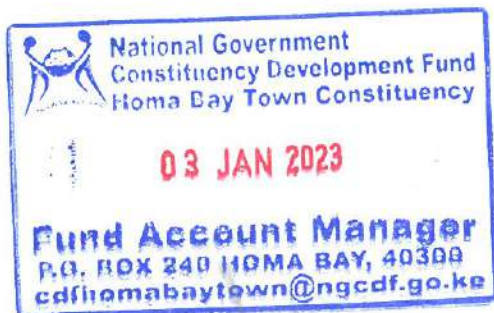

**FOURTH SCHEDULE (s. 30)
PROJECT DESCRIPTION FORM**

Constituency No 249
 Constituency Name HOMA BAY TOWN County Homa Bay
 Project Number 2710102
 Project Title Gratuity - Contractual Employees
 Sector Administration & Recurrent

Status of projects

Brief statement on project status at time of submission

Financial year 2022-07-01 to 2023-07-31

Original Cost Estimates, in Ksh 657,250.00 dated

Amount allocated last financial year dated

Sub projects

Project Name	Project Code	Activity	Original Status	Amount (Ksh)
Staff Gratuity	4-0043-249-2710102-100-2022-2023-2	Payment of staff gratuity for 7 staff	New Project	657,250.00
			TOTAL:	657,250.00

Person completing form

SIGNATURE: _____

DATE: _____

NAME: _____

POSITION: _____



FOURTH SCHEDULE (s. 30) PROJECT DESCRIPTION FORM

Constituency No 249
Constituency Name HOMA BAY TOWN County Homa Bay
Project Number 2120101
Project Title NSSF
Sector Administration & Recurrent

Status of projects

Brief statement on project status at time of submission

Financial year 2022-07-01 to 2023-07-31
Original Cost Estimates, in Ksh 16,800.00 dated
Amount allocated last financial year dated

Sub projects

Project Name	Project Code	Activity	Original Status	Amount (Ksh)
NSSF	4-0043-249-2120101-100-2022-2023-3	Payment of NSSF employer deductions for 7 staff	New Project	16,800.00
TOTAL:				16,800.00

Person completing form

SIGNATURE: [Signature] DATE: 10.1.23
NAME: Wilson Okumu POSITION: FAM



**FOURTH SCHEDULE (s. 30)
PROJECT DESCRIPTION FORM**

Constituency No 249
Constituency Name HOMA BAY TOWN County Homa Bay
Project Number 2110202
Project Title Admin Casual Labour and Internship
Sector Administration & Recurrent

Status of projects

Brief statement on project status at time of submission

Financial year 2022-07-01 to 2023-07-31

Original Cost Estimates, in Ksh 360,000.00 dated

Amount allocated last financial year dated

Sub projects

Project Name	Project Code	Activity	Original Status	Amount (Ksh)
Casual labour and Internship	4-0043-249-2110202-100-2022-2023-4	Payment of staff Basic Wages	New Project	360,000.00
			TOTAL:	360,000.00

Person completing form

SIGNATURE: [Signature] DATE: 10 / 1 / 23

NAME: Walter Oluoch POSITION: FAM



**FOURTH SCHEDULE (s. 30)
PROJECT DESCRIPTION FORM**

Constituency No 249
Constituency Name HOMA BAY TOWN County Homa Bay
Project Number 2210101
Project Title Electricity
Sector Administration & Recurrent

Status of projects

Brief statement on project status at time of submission

Financial year 2022-07-01 to 2023-07-31

Original Cost Estimates, in Ksh 72,000.00 dated

Amount allocated last financial year dated

Sub projects

Project Name	Project Code	Activity	Original Status	Amount (Ksh)
Electricity charges	4-0043-249-2210101-100-2022-2023-5	Payment of Electricity charges	New Project	72,000.00
TOTAL:				72,000.00

Person completing form

SIGNATURE: [Signature] DATE: 10 / 1 / 23
NAME: Wilson Okumu POSITION: FAM



**FOURTH SCHEDULE (s. 30)
PROJECT DESCRIPTION FORM**

Constituency No 249
 Constituency Name HOMA BAY TOWN County Homa Bay
 Project Number 2210102
 Project Title Water
 Sector Administration & Recurrent

Status of projects

Brief statement on project status at time of submission

Financial year 2022-07-01 to 2023-07-31

Original Cost Estimates, in Ksh 14,400.00 dated

Amount allocated last financial year dated

Sub projects

Project Name	Project Code	Activity	Original Status	Amount (Ksh)
Water & sewerage charges	4-0043-249-2210102-100-2022-2023-6	Payment of Water & sewerage charges	New Project	14,400.00
			TOTAL:	14,400.00

Person completing form

SIGNATURE:



DATE:

10 / 1 / 23

NAME:

Wilson Othman

POSITION:

Fan



**FOURTH SCHEDULE (s. 30)
PROJECT DESCRIPTION FORM**

Constituency No 249

Constituency Name HOMA BAY TOWN County Homa Bay

Project Number 2210201

Project Title Telephone, Telex, Facsimile and Mobile Phone Service expense

Sector Administration & Recurrent

States of projects

Brief statement on project status at time of submission

Financial year 2022-07-01 to 2023-07-31

Original Cost Estimates, in Ksh 120,000.00 dated

Amount allocated last financial year dated

Sub projects

Project Name	Project Code	Activity	Original Status	Amount (Ksh)
Telephone, Telex, Facsimile and Mobile Phone Service	4-0043-249-2210201-100-2022-2023-7	Payment of Telephone expenses	New Project	120,000.00
			TOTAL:	120,000.00

Person completing form

SIGNATURE: *[Signature]* DATE: 10 / 1 / 23

NAME: Wilson Othman POSITION: FAC



**FOURTH SCHEDULE (s. 30)
PROJECT DESCRIPTION FORM**

Constituency No 249
 Constituency Name HOMA BAY TOWN County Homa Bay
 Project Number 2210202
 Project Title Internet Connections
 Sector Administration & Recurrent

Status of projects

Brief statement on project status at time of submission

Financial year 2022-07-01 to 2023-07-31
 Original Cost Estimates, in Ksh 60,000.00 dated
 Amount allocated last financial year dated

Sub projects

Project Name	Project Code	Activity	Original Status	Amount (Ksh)
Internet Connections	4-0043-249-2210202-100-2022-2023-8	Payment of Internet Connections	New Project	60,000.00
			TOTAL:	60,000.00

Person completing form

SIGNATURE: [Signature] DATE: 12 / 1 / 23
 NAME: WILSON OKUMU POSITION: FAM



FOURTH SCHEDULE (s. 30) PROJECT DESCRIPTION FORM

Constituency No 249
Constituency Name HOMA BAY TOWN County Homa Bay
Project Number 2210203
Project Title Courier and Postal Services
Sector Administration & Recurrent

Status of projects

Brief statement on project status at time of submission

Financial year 2022-07-01 to 2023-07-31
Original Cost Estimates, in Ksh 250,000.00 dated
Amount allocated last financial year dated

Sub projects

Project Name	Project Code	Activity	Original Status	Amount (Ksh)
Courier and Postal Services	4-0043-249-2210203-100-2022-2023-9	Payment of Courier and Postal Services	New Project	250,000.00
			TOTAL:	250,000.00

Person completing form

SIGNATURE:

[Handwritten Signature]
Wilson Okumu

DATE:

10 / 1 / 23

NAME:

POSITION:

FAM



**FOURTH SCHEDULE (s. 30)
PROJECT DESCRIPTION FORM**

Constituency No 249
Constituency Name HOMA BAY TOWN County Homa Bay
Project Number 2210502
Project Title Publishing and Printing Services
Sector Administration & Recurrent

Status of projects

Brief statement on project status at time of submission

Financial year 2022-07-01 to 2023-07-31
Original Cost Estimates, in Ksh 300,000.00 dated
Amount allocated last financial year dated
Sub projects

Project Name	Project Code	Activity	Original Status	Amount (Ksh)
Publishing and Printing Services	4-0043-249-2210502-100-2022-2023-10	Payment of Publishing and Printing Services	New Project	300,000.00
TOTAL:				300,000.00

Person completing form

SIGNATURE: _____

[Handwritten Signature]
Wilson Okumu

DATE: _____

03 / 01 / 2023

NAME: _____

POSITION: _____

FAM



**FOURTH SCHEDULE (s. 30)
PROJECT DESCRIPTION FORM**

Constituency No 249
 Constituency Name HOMA BAY TOWN County Homa Bay
 Project Number 2210503
 Project Title Subscriptions to Newspapers, Magazines and Periodicals
 Sector Administration & Recurrent

Status of projects

Brief statement on project status at time of submission

Financial year 2022-07-01 to 2023-07-31
 Original Cost Estimates, in Ksh 43,200.00 dated
 Amount allocated last financial year dated

Sub projects

Project Name	Project Code	Activity	Original Status	Amount (Ksh)
Subscriptions to Newspapers, Magazines and Periodicals	4-0043-249-2210503-100-2022-2023-11	Payment of Subscriptions to Newspapers, Magazines and Periodicals	New Project	43,200.00
			TOTAL:	43,200.00

Person completing form

SIGNATURE: [Signature] DATE: 10 / 1 / 23
 NAME: Wilson Othman POSITION: FAM



**FOURTH SCHEDULE (s. 30)
PROJECT DESCRIPTION FORM**

Constituency No 249
Constituency Name HOMA BAY TOWN County Homa Bay
Project Number 2210504
Project Title Advertising, Awareness and Publicity Campaigns
Sector Administration & Recurrent

Status of projects

Brief statement on project status at time of submission

Financial year 2022-07-01 to 2023-07-31
Original Cost Estimates, in Ksh 250,000.00 dated
Amount allocated last financial year dated

Sub projects

Project Name	Project Code	Activity	Original Status	Amount (Ksh)
Advertising, Awareness and Publicity Campaigns	4-0043-249-2210504-100-2022-2023-12	Payment of Advertising, Awareness and Publicity Campaigns	New Project	250,000.00
			TOTAL:	250,000.00

Person completing form

SIGNATURE: [Signature] DATE: 10 / 1 / 23
NAME: Wilson Okun POSITION: FAM



**FOURTH SCHEDULE (s. 30)
PROJECT DESCRIPTION FORM**

Constituency No 249
Constituency Name HOMA BAY TOWN County Homa Bay
Project Number 2210801
Project Title Catering Services (receptions),
Accommodation, Gifts, Food and Drinks
Sector Administration & Recurrent

Status of projects

Brief statement on project status at time of submission

Financial year 2022-07-01 to 2023-07-31
Original Cost Estimates, in Ksh 240,000.00 dated
Amount allocated last financial year dated
Sub projects

Project Name	Project Code	Activity	Original Status	Amount (Ksh)
Catering Services (receptions), Accommodation, Gifts, Food and Drinks	4-0043-249-2210801-100-2022-2023-13	Payment of catering Services (receptions), Accommodation, Gifts, Food and Drinks	New Project	240,000.00
			TOTAL:	240,000.00

Person completing form

SIGNATURE:  DATE: 03 / 01 / 2023
NAME: Wilton Okumu POSITION: FAM



**FOURTH SCHEDULE (s. 30)
PROJECT DESCRIPTION FORM**

Constituency No 249
Constituency Name HOMA BAY TOWN County Homa Bay
Project Number 2211102
Project Title Supplies and Accessories for Computers and Printers
Sector Administration & Recurrent

Status of projects

Brief statement on project status at time of submission

Financial year 2022-07-01 to 2023-07-31

Original Cost Estimates, in Ksh 300,000.00 dated

Amount allocated last financial year dated

Sub projects

Project Name	Project Code	Activity	Original Status	Amount (Ksh)
Supplies and Accessories for Computers and Printers	4-0043-249-2211102-100-2022-2023-14	Purchase of Supplies and Accessories for Computers and Printers	New Project	300,000.00
			TOTAL:	300,000.00

Person completing form

SIGNATURE:

DATE:

10 / 1 / 23

NAME:

Wilson Okumu

POSITION:

FAM



**FOURTH SCHEDULE (s. 30)
PROJECT DESCRIPTION FORM**

Constituency No 249
Constituency Name HOMA BAY TOWN County Homa Bay
Project Number 2211103
Project Title Sanitary and Cleaning Materials, supplies and Services
Sector Administration & Recurrent

Status of projects

Brief statement on project status at time of submission

Financial year 2022-07-01 to 2023-07-31

Original Cost Estimates, in Ksh 55,000.00 dated

Amount allocated last financial year dated

Sub projects

Project Name	Project Code	Activity	Original Status	Amount (Ksh)
Sanitary and Cleaning Materials, Supplies and Services	4-0043-249-2211103-100-2022-2023-15	Purchase of Sanitary and Cleaning Materials, Supplies and Services	New Project	55,000.00
			TOTAL:	55,000.00

Person completing form

SIGNATURE: _____

DATE: 10 / 1 / 23

NAME: _____

POSITION: _____



**FOURTH SCHEDULE (s. 30)
PROJECT DESCRIPTION FORM**

Constituency No 249
Constituency Name HOMA BAY TOWN County Homa Bay
Project Number 2210403
Project Title Daily Subsistence Allowance
Sector Administration & Recurrent

Status of projects

Brief statement on project status at time of submission

Financial year 2022-07-01 to 2023-07-31

Original Cost Estimates, in Ksh 635,000.00 dated

Amount allocated last financial year dated

Sub projects

Project Name	Project Code	Activity	Original Status	Amount (Ksh)
Daily Subsistence Allowance	4-0043-249-2210403-100-2022-2023-16	Payment of Daily Subsistence Allowance	New Project	635,000.00
			TOTAL:	635,000.00

Person completing form

SIGNATURE:



DATE:

10 / 1 / 23

NAME:

Wilson Okumu

POSITION:

FAM



**FOURTH SCHEDULE (s. 30)
PROJECT DESCRIPTION FORM**

Constituency No 249
Constituency Name HOMA BAY TOWN County Homa Bay
Project Number 2210304
Project Title Sundry Items (e.g. airport tax, taxis, etc ...)
Sector Administration & Recurrent

Status of projects

Brief statement on project status at time of submission

Financial year 2022-07-01 to 2023-07-31
Original Cost Estimates, in Ksh 40,000.00 dated
Amount allocated last financial year dated

Sub projects

Project Name	Project Code	Activity	Original Status	Amount (Ksh)
Sundry Items (taxis)	4-0043-249-2210304-100-2022-2023-17	Payment of sundry items (airport transfer, taxis, expenses)	New Project	40,000.00
TOTAL:				40,000.00

Person completing form

SIGNATURE: [Signature] DATE: 10 / 1 / 23
NAME: WILSON OJUMA POSITION: FAM



**FOURTH SCHEDULE (s. 30)
PROJECT DESCRIPTION FORM**

Constituency No 249
Constituency Name HOMA BAY TOWN County Homa Bay
Project Number 2210604
Project Title Hire of Transport
Sector Administration & Recurrent

Status of projects

Brief statement on project status at time of submission

Financial year 2022-07-01 to 2023-07-31
Original Cost Estimates, in Ksh 846,920.00 dated
Amount allocated last financial year dated
Sub projects

Project Name	Project Code	Activity	Original Status	Amount (Ksh)
Hire of Transport	4-0043-249-2210604-100-2022-2023-18	Payment of Hire of Transport	New Project	846,920.00
TOTAL:				846,920.00

Person completing form

SIGNATURE:  DATE: 03, 01, 2023
NAME: Wilson Okumu POSITION: FAM



**FOURTH SCHEDULE (s. 30)
PROJECT DESCRIPTION FORM**

Constituency No 249
Constituency Name HOMA BAY TOWN County Homa Bay
Project Number 2211201
Project Title Refined Fuels and Lubricants for Transport
Sector Administration & Recurrent

Status of projects

Brief statement on project status at time of submission

Financial year 2022-07-01 to 2023-07-31
Original Cost Estimates, in Ksh 300,000.00 dated
Amount allocated last financial year dated

Sub projects

Project Name	Project Code	Activity	Original Status	Amount (Ksh)
Refined Fuels and Lubricants	4-0043-249-2211201-100-2022-2023-19	Purchase of Refined Fuels and Lubricants	New Project	300,000.00
			TOTAL:	300,000.00

Person completing form

SIGNATURE:  DATE: 03 / 01 / 2023
NAME: Wilson Oduku POSITION: FAM

National Government
Constituency Development Fund
Homa Bay Town Constituency
03 JAN 2023
Fund Account Manager
P.O. BOX 240 HOMA BAY, KUUNYA
cdfhomabaytown@ngcdf.go.ke

**FOURTH SCHEDULE (s. 30)
PROJECT DESCRIPTION FORM**

Constituency No 249
 Constituency Name HOMA BAY TOWN County Homa Bay
 Project Number 2210811
 Project Title NGCDFC Allowance
 Sector Administration & Recurrent

Status of projects

Brief statement on project status at time of submission

Financial year 2022-07-01 to 2023-07-31
 Original Cost Estimates, in Ksh 1,128,000.00 dated
 Amount allocated last financial year dated
 Sub projects

Project Name	Project Code	Activity	Original Status	Amount (Ksh)
Committee Expenses	4-0043-249-2210811-100-2022-2023-20	Payment of committee sitting allowances, transport, conferences	New Project	1,128,000.00
			TOTAL:	1,128,000.00

Person completing form

SIGNATURE:  DATE: 03 / 01 / 2023
 NAME: Wilson Okumu POSITION: FAM



FOURTH SCHEDULE (s. 30) PROJECT DESCRIPTION FORM

Constituency No 249
Constituency Name HOMA BAY TOWN County Homa Bay
Project Number 2210802
Project Title Committee Expenses
Sector Administration & Recurrent

Status of projects

Brief statement on project status at time of submission

Financial year 2022-07-01 to 2023-07-31
Original Cost Estimates, in Ksh 406,322.31 dated
Amount allocated last financial year dated
Sub projects

Project Name	Project Code	Activity	Original Status	Amount (Ksh)
Other committee expenses	4-0043-249-2210802-100-2022-2023-21	Payment of other committee expenses	New Project	406,322.31
TOTAL:				406,322.31

Person completing form

SIGNATURE:  DATE: 03 / 01 / 2023
NAME: Wilson Okumu POSITION: FAM



**FOURTH SCHEDULE (s. 30)
PROJECT DESCRIPTION FORM**

Constituency No 249
 Constituency Name HOMA BAY TOWN County Homa Bay
 Project Number AP1
 Project Title Monitoring and Evaluation
 Sector Monitoring & Evaluation

Status of projects

Brief statement on project status at time of submission

Financial year 2022-07-01 to 2023-07-31
 Original Cost Estimates, in Ksh 4,146,400.99 dated
 Amount allocated last financial year dated

Sub projects

Project Name	Project Code	Activity	Original Status	Amount (Ksh)
Travel Costs	4-0043-249-2210301-111-2022-2023-2	Payment of Transport Expenses	New Project	650,000.00
Daily Subsistence Allowance	4-0043-249-2210303-111-2022-2023-3	Payment of Daily Subsistence Allowance	New Project	366,000.00
Publishing and Printing Services	4-0043-249-2210502-111-2022-2023-4	Payment of Publishing and Printing Services	New Project	160,000.00
Hire of Transport	4-0043-249-2210604-111-2022-2023-5	Payment of Hire of Transport	New Project	300,000.00
Travel Allowance on training	4-0043-249-2210701-111-2022-2023-6	Payment of Travel Allowance of NG-CDFC, National Government officers and PMC (project management, procurement and cross cutting issues)	New Project	500,000.00
Remuneration of Instructors and Contract Based Training Services	4-0043-249-2210702-111-2022-2023-7	Payment of Instructors and Contract Based Training Services NG-CDFC related issues and cross cutting issues)	New Project	160,000.00
Hire of Training Facilities and Equipment	4-0043-249-2210704-111-2022-2023-8	Hire of Training Facilities and Equipment (project management, procurement and cross cutting issues)	New Project	254,400.99
Accommodation Allowance	4-0043-249-2210402-111-2022-2023-9	Payment of Accommodation Allowance of NGCDFC, National Government officers and PMC (project management, procurement and cross cutting issues)	New Project	250,000.00

National Government Constituency Development Fund
 Homa Bay Town Constituency
 03 JAN 2023
 Fund Account Manager
 P.O. BOX 240 HOMA BAY, 40300
 cdfhomabaytown@ngcdf.go.ke

National Government Constituencies Development Fund
Fourth Schedule Report

		issues)		
Catering Services (receptions), Accommodation, Gifts, Food and Drinks)	4-0043-249-2210801-111-2022-2023-11	Payment of catering Services (receptions), Accommodation, Gifts, Food and Drinks	New Project	224,000.00
Other committee expenses	4-0043-249-2210802-111-2022-2023-12	Payment of Other committee expenses	New Project	200,000.00
Purchase of Uniforms and Clothing - Staff	4-0043-249-2211016-111-2022-2023-13	Purchase of Uniforms and Clothing - Staff	New Project	150,000.00
Maintenance Expenses - Motor Cycles	4-0043-249-2220101-111-2022-2023-14	Payment of Maintenance Expenses - NG-CDFC - Motor Cycles	New Project	110,000.00
Refined Fuels and Lubricants for Transport	4-0043-249-2211201-111-2022-2023-15	Purchase of Refined Fuels and Lubricants for Transport of GK vehicles	New Project	140,000.00
General Office Supplies (papers, pencils, forms, small office equipment)	4-0043-249-2211101-111-2022-2023-16	Purchase of General Office Supplies (papers, pencils, forms, small office equipment)	New Project	170,000.00
NGCDFC allowance	4-0043-249-2210811-111-2022-2023-17	Payment of NG-CDFC allowances during M&E exercise	New Project	416,000.00
Production and Printing of Training Materials	4-0043-249-2210703-111-2022-2023-18	Payment of Production and Printing of Training Materials (project management, procurement and cross cutting issues)	New Project	96,000.00
TOTAL:				4,146,400.99

Person completing form

SIGNATURE: _____

DATE: _____

NAME: _____

POSITION: _____

[Handwritten Signature]
Wilson Owen
 10 / 1 / 23
FAN



**FOURTH SCHEDULE (s. 30)
PROJECT DESCRIPTION FORM**

Constituency No 249

Constituency Name HOMA BAY TOWN County Homa Bay

Project Number 2210301

Project Title Travel Costs (airlines, bus, railway, mileage allowances, etc.)

Sector Monitoring & Evaluation

Status of projects

Brief statement on project status at time of submission

Financial year 2022-07-01 to 2023-07-31

Original Cost Estimates, in Ksh 650,000.00 dated

Amount allocated last financial year dated

Sub projects

Project Name	Project Code	Activity	Original Status	Amount (Ksh)
Travel Costs	4-0043-249-2210301-111-2022-2023-2	Payment of Transport Expenses	New Project	650,000.00
			TOTAL:	650,000.00

Person completing form

SIGNATURE:

[Handwritten Signature]

DATE:

10 / 1 / 23

NAME:

Wilson Oduor

POSITION:

FAM



**FOURTH SCHEDULE (s. 30)
PROJECT DESCRIPTION FORM**

Constituency No 249
Constituency Name HOMA BAY TOWN County Homa Bay
Project Number 2210303
Project Title Daily Subsistence Payment of Daily Subsistence Allowance
Sector Monitoring & Evaluation

Status of projects

Brief statement on project status at time of submission

Financial year 2022-07-01 to 2023-07-31
Original Cost Estimates, in Ksh 366,000.00 dated
Amount allocated last financial year dated
Sub projects

Project Name	Project Code	Activity	Original Status	Amount (Ksh)
Daily Subsistence Allowance	4-0043-249-2210303-111-2022-2023-3	Payment of Daily Subsistence Allowance	New Project	366,000.00
			TOTAL:	366,000.00

Person completing form

SIGNATURE:  DATE: 02 / 01 / 2023
NAME: Wilson Okumu POSITION: FAM



FOURTH SCHEDULE (s. 30) PROJECT DESCRIPTION FORM

Constituency No 249
Constituency Name HOMA BAY TOWN County Homa Bay
Project Number 2210502
Project Title Publishing and Printing Services
Sector Monitoring & Evaluation

Status of projects

Brief statement on project status at time of submission

Financial year 2022-07-01 to 2023-07-31
Original Cost Estimates, in Ksh 160,000.00 dated
Amount allocated last financial year dated
Sub projects

Project Name	Project Code	Activity	Original Status	Amount (Ksh)
Publishing and Printing Services	4-0043-249-2210502-111-2022-2023-4	Payment of Publishing and Printing Services	New Project	160,000.00
			TOTAL:	160,000.00

Person completing form

SIGNATURE:  DATE: 03 / 01 / 2023
NAME: Wilson Okumu POSITION: F&M



**FOURTH SCHEDULE (s. 30)
PROJECT DESCRIPTION FORM**

Constituency No 249
Constituency Name HOMA BAY TOWN County Homa Bay
Project Number 2210604
Project Title Hire of Transport
Sector Monitoring & Evaluation

Status of projects

Brief statement on project status at time of submission

Financial year 2022-07-01 to 2023-07-31
Original Cost Estimates, in Ksh 300,000.00 dated
Amount allocated last financial year dated

Sub projects

Project Name	Project Code	Activity	Original Status	Amount (Ksh)
Hire of Transport	4-0043-249-2210604-111-2022-2023-5	Payment of Hire of Transport	New Project	300,000.00
TOTAL:				300,000.00

Person completing form

SIGNATURE: [Signature] DATE: 03 / 01 / 2023
NAME: Wilson Okumu POSITION: FAM



FOURTH SCHEDULE (s. 30) PROJECT DESCRIPTION FORM

Constituency No 249
Constituency Name HOMA BAY TOWN County Homa Bay
Project Number 2210701
Project Title Travel Allowance on training
Sector Monitoring & Evaluation

Status of projects

Brief statement on project status at time of submission

Financial year 2022-07-01 to 2023-07-31

Original Cost Estimates, in Ksh 500,000.00 dated

Amount allocated last financial year dated

Sub projects

Project Name	Project Code	Activity	Original Status	Amount (Ksh)
Travel Allowance on training	4-0043-249-2210701-111-2022-2023-6	Payment of Travel Allowance of NG-CDFC, National Government officers and PMC (project management, procurement and cross cutting issues)	New Project	500,000.00
			TOTAL:	500,000.00

Person completing form

SIGNATURE: 

DATE: 10 / 1 / 23

NAME: Wilson Okumu

POSITION: 



**FOURTH SCHEDULE (s. 30)
PROJECT DESCRIPTION FORM**

Constituency No 249
Constituency Name HOMA BAY TOWN County Homa Bay
Project Number 2210702
Project Title Remuneration of Instructors and Contract Based Training Services
Sector Monitoring & Evaluation

Status of projects

Brief statement on project status at time of submission

Financial year 2022-07-01 to 2023-07-31

Original Cost Estimates, in Ksh 160,000.00 dated

Amount allocated last financial year dated

Sub projects

Project Name	Project Code	Activity	Original Status	Amount (Ksh)
Remuneration of Instructors and Contract Based Training Services	4-0043-249-2210702-111-2022-2023-7	Payment of Instructors and Contract Based Training Services NG-CDFC related issues and cross cutting issues)	New Project	160,000.00
			TOTAL:	160,000.00

Person completing form

SIGNATURE: _____

DATE: _____

NAME: _____

POSITION: _____



**FOURTH SCHEDULE (s. 30)
PROJECT DESCRIPTION FORM**

Constituency No 249
 Constituency Name HOMA BAY TOWN County Homa Bay
 Project Number 2210704
 Project Title Hire of Training Facilities and Equipment
 Sector Monitoring & Evaluation

Status of projects

Brief statement on project status at time of submission

Financial year 2022-07-01 to 2023-07-31

Original Cost Estimates, in Ksh 254,400.99 dated

Amount allocated last financial year dated

Sub projects

Project Name	Project Code	Activity	Original Status	Amount (Ksh)
Hire of Training Facilities and Equipment	4-0043-249-2210704-111-2022-2023-8	Hire of Training Facilities and Equipment (project management, procurement and cross cutting issues)	New Project	254,400.99
			TOTAL:	254,400.99

Person completing form

SIGNATURE: [Signature] DATE: 10 / 1 / 2023

NAME: Walter Oluoch POSITION: FACU.



FOURTH SCHEDULE (s. 30) PROJECT DESCRIPTION FORM

Constituency No 249
Constituency Name HOMA BAY TOWN County Homa Bay
Project Number 2210402
Project Title Accommodation
Sector Monitoring & Evaluation

Status of projects

Brief statement on project status at time of submission

Financial year 2022-07-01 to 2023-07-31
Original Cost Estimates, in Ksh 250,000.00 dated
Amount allocated last financial year dated

Sub projects

Project Name	Project Code	Activity	Original Status	Amount (Ksh)
Accommodation Allowance	4-0043-249-2210402-111-2022-2023-9	Payment of Accommodation Allowance of NGCDFC, National Government officers and PMC (project management, procurement and cross cutting issues)	New Project	250,000.00
			TOTAL:	250,000.00

Person completing form

SIGNATURE:  DATE: 23 / 01 / 2023
NAME: Wilson Okumu POSITION: FAFM



**FOURTH SCHEDULE (s. 30)
PROJECT DESCRIPTION FORM**

Constituency No 249
Constituency Name HOMA BAY TOWN County Homa Bay
Project Number 2210801
Project Title Catering Services (receptions),
Accommodation, Gifts, Food and Drinks
Sector Monitoring & Evaluation

Status of projects

Brief statement on project status at time of submission

Financial year 2022-07-01 to 2023-07-31
Original Cost Estimates, in Ksh 224,000.00 dated
Amount allocated last financial year dated

Sub projects

Project Name	Project Code	Activity	Original Status	Amount (Ksh)
Catering Services (receptions), Accommodation, Gifts, Food and Drinks)	4-0043-249-2210801-111-2022-2023-11	Payment of catering Services (receptions), Accommodation, Gifts, Food and Drinks	New Project	224,000.00
TOTAL:				224,000.00

Person completing form

SIGNATURE:  DATE: 03 / 01 / 2023
NAME: Wilson Okumu POSITION: FAM



FOURTH SCHEDULE (s. 30) PROJECT DESCRIPTION FORM

Constituency No 249

Constituency Name HOMA BAY TOWN County Homa Bay

Project Number 2210802

Project Title Committee Expenses

Sector Monitoring & Evaluation

Status of projects

Brief statement on project status at time of submission

Financial year 2022-07-01 to 2023-07-31

Original Cost Estimates, in Ksh 200,000.00 dated

Amount allocated last financial year dated

Sub projects

Project Name	Project Code	Activity	Original Status	Amount (Ksh)
Other committee expenses	4-0043-249-2210802-111-2022-2023-12	Payment of Other committee expenses	New Project	200,000.00
TOTAL:				200,000.00

Person completing form

SIGNATURE:  DATE: 03 / 01 / 2023

NAME: Hikson Okumu POSITION: FKM



**FOURTH SCHEDULE (s. 30)
PROJECT DESCRIPTION FORM**

Constituency No 249
Constituency Name HOMA BAY TOWN County Homa Bay
Project Number 2211016
Project Title Purchase of Uniforms and Clothing -Staff
Sector Monitoring & Evaluation

Status of projects

Brief statement on project status at time of submission

Financial year 2022-07-01 to 2023-07-31
Original Cost Estimates, in Ksh 150,000.00 dated
Amount allocated last financial year dated

Sub projects

Project Name	Project Code	Activity	Original Status	Amount (Ksh)
Purchase of Uniforms and Clothing - Staff	4-0043-249-2211016-111-2022-2023-13	Purchase of Uniforms and Clothing - Staff	New Project	150,000.00
			TOTAL:	150,000.00

Person completing form

SIGNATURE: [Signature] DATE: 10 / 1 / 23
NAME: Wilson Oluo POSITION: FAN



**FOURTH SCHEDULE (s. 30)
PROJECT DESCRIPTION FORM**

Constituency No 249
Constituency Name HOMA BAY TOWN County Homa Bay
Project Number 2220101
Project Title Maintenance Expenses ~ Motor Vehicles
Sector Monitoring & Evaluation

Status of projects

Brief statement on project status at time of submission

Financial year 2022-07-01 to 2023-07-31

Original Cost Estimates, in Ksh 110,000.00 dated

Amount allocated last financial year dated

Sub projects

Project Name	Project Code	Activity	Original Status	Amount (Ksh)
Maintenance Expenses - Motor Cycles	4-0043-249-2220101-111-2022-2023-14	Payment of Maintenance Expenses - NG-CDFC - Motor Cycles	New Project	110,000.00
TOTAL:				110,000.00

Person completing form

SIGNATURE:  DATE: 10 / 1 / 23
NAME: Wilson Orom POSITION: FAM



**FOURTH SCHEDULE (s. 30)
PROJECT DESCRIPTION FORM**

Constituency No 249
Constituency Name HOMA BAY TOWN County Homa Bay
Project Number 2211201
Project Title Refined Fuels and Lubricants for Transport
Sector Monitoring & Evaluation

Status of projects

Brief statement on project status at time of submission

Financial year 2022-07-01 to 2023-07-31
Original Cost Estimates, in Ksh 140,000.00 dated
Amount allocated last financial year dated
Sub projects

Project Name	Project Code	Activity	Original Status	Amount (Ksh)
Refined Fuels and Lubricants for Transport	4-0043-249-2211201-111-2022-2023-15	Purchase of Refined Fuels and Lubricants for Transport of GK vehicles	New Project	140,000.00
			TOTAL:	140,000.00

Person completing form

SIGNATURE: *Wilson Okumu* DATE: 03, 01, 2023
NAME: Wilson Okumu POSITION: FAM



**FOURTH SCHEDULE (s. 30)
PROJECT DESCRIPTION FORM**

Constituency No 249
 Constituency Name HOMA BAY TOWN County Homa Bay
 Project Number 2211101
 Project Title General Office Supplies (papers, pencils, forms, small office equipment etc)
 Sector Monitoring & Evaluation

Status of projects

Brief statement on project status at time of submission

Financial year 2022-07-01 to 2023-07-31
 Original Cost Estimates, in Ksh 170,000.00 dated
 Amount allocated last financial year dated
 Sub projects

Project Name	Project Code	Activity	Original Status	Amount (Ksh)
General Office Supplies (papers, pencils, forms, small office equipment)	4-0043-249-2211101-111-2022-2023-16	Purchase of General Office Supplies (papers, pencils, forms, small office equipment)	New Project	170,000.00
			TOTAL:	170,000.00

Person completing form

SIGNATURE: [Signature] DATE: 10 / 1 / 23
 NAME: W/John O'Kun POSITION: fan



FOURTH SCHEDULE (s. 30) PROJECT DESCRIPTION FORM

Constituency No 249
Constituency Name HOMA BAY TOWN County Homa Bay
Project Number 2210811
Project Title NGCDFC Allowance
Sector Monitoring & Evaluation

Status of projects

Brief statement on project status at time of submission

Financial year 2022-07-01 to 2023-07-31
Original Cost Estimates, in Ksh 416,000.00 dated
Amount allocated last financial year dated
Sub projects

Project Name	Project Code	Activity	Original Status	Amount (Ksh)
NG-CDFC Allowance	4-0043-249-2210811-111-2022-2023-17	Payment of NG-CDFC allowances during M&E exercise	New Project	416,000.00
			TOTAL:	416,000.00

Person completing form

SIGNATURE: [Signature] DATE: 03 / 01 / 2023
NAME: Wilson Okumu POSITION: FAM



FOURTH SCHEDULE (s. 30)
PROJECT DESCRIPTION FORM

Constituency No 249
Constituency Name HOMA BAY TOWN County Homa Bay
Project Number 2210703
Project Title Production and Printing of Training Materials
Sector Monitoring & Evaluation

Status of projects

Brief statement on project status at time of submission

Financial year 2022-07-01 to 2023-07-31
Original Cost Estimates, in Ksh 96,000.00 dated
Amount allocated last financial year dated
Sub projects

Project Name	Project Code	Activity	Original Status	Amount (Ksh)
Production and Printing of Training Materials	4-0043-249-2210703-111-2022-2023-18	Payment of Production and Printing of Training Materials (project management, procurement and cross cutting issues)	New Project	96,000.00
TOTAL:				96,000.00

Person completing form

SIGNATURE:  DATE: 10 / 1 / 23

NAME: Wilson Okumu POSITION: FOM



FOURTH SCHEDULE (s. 30)
PROJECT DESCRIPTION FORM

Constituency No 249
Constituency Name HOMA BAY TOWN County Homa Bay
Project Number 2640100
Project Title Bursary/Mocks/Cats
Sector Bursary

Status of projects

Brief statement on project status at time of submission

Financial year 2022-07-01 to 2023-07-31

Original Cost Estimates, in Ksh 35,700,000.00 dated

Amount allocated last financial year dated

Sub projects

Project Name	Project Code	Activity	Original Status	Amount (Ksh)
Bursary Secondary Schools	4-0043-249-2640101-103-2022-2023-1	Bursary to cater for needy students in Secondary Schools	New Project	27,000,000.00
Bursary - Tertiary institutions (universities and Colleges)	4-0043-249-2640102-103-2022-2023-2	Bursary funds to cater for needy students in tertiary Institutions.	New Project	8,000,000.00
Bursary - Special Schools	4-0043-249-2640105-103-2022-2023-3	Bursary funds to cater for needy students in special Schools and Institutions.	New Project	700,000.00
			TOTAL:	35,700,000.00

Person completing form

SIGNATURE: _____

DATE: _____

NAME: _____

POSITION: _____



FOURTH SCHEDULE (s. 30) PROJECT DESCRIPTION FORM

Constituency No 249
Constituency Name HOMA BAY TOWN County Homa Bay
Project Number 2640200
Project Title Emergency projects
Sector Emergency

Status of projects

Brief statement on project status at time of submission

Financial year 2022-07-01 to 2023-07-31
Original Cost Estimates, in Ksh 7,636,190.00 dated
Amount allocated last financial year dated

Sub projects

Project Name	Project Code	Activity	Original Status	Amount (Ksh)
Emergency	4-0043-249-2640200-101-2022-2023-1	To cater for unforeseen occurrences in the Constituency during the Financial Year	New Project	7,636,190.00
TOTAL:				7,636,190.00

Person completing form

SIGNATURE: _____

DATE: 10 / 1 / 23

NAME: Wilson Okumu

POSITION: FOM



FOURTH SCHEDULE (s. 30) PROJECT DESCRIPTION FORM

Constituency No 249

Constituency Name HOMA BAY TOWN County Homa Bay

Project Number 2630204

Project Title Primary School Projects

Sector Education

Status of projects

Brief statement on project status at time of submission

Financial year 2022-07-01 to 2023-07-31

Original Cost Estimates, in Ksh 33,895,482.38 dated

Amount allocated last financial year dated

Sub projects

Project Name	Project Code	Activity	Original Status	Amount (Ksh)
Otaru Primary School	4-0043-249-2630204-104-2022-2023-1	Fencing of 2.5 acres with concrete poles and six strands barbed wire complete with chainlink to completion	New Project	1,350,000.00
Shauri Yako Primary School	4-0043-249-2630204-104-2022-2023-2	Completion of a storey building of 4 Classrooms Construction of the superstructure wall, reinforced concrete superstructure, Roofing, fittings of windows and doors complete with glazing and iron mongery, electrical installation, plastering, painting and tiling	Ongoing Project	3,841,295.00
Disii Primary School	4-0043-249-2630204-104-2022-2023-3	Completion of administration block consisting of 3 offices and a staff room Tiling and painting	Ongoing Project	524,850.00
Ogande Primary School	4-0043-249-2630204-104-2022-2023-4	Completion of 3No. Classrooms Fixing of fascia board and painting	Ongoing Project	208,900.00
Rodi Primary School	4-0043-249-2630204-104-2022-2023-5	Completion of administration block consisting of 4 offices and a staff room Tiling, painting, electrical works and project branding	Ongoing Project	497,860.00
Ndori Primary School	4-0043-249-2630204-104-2022-2023-6	Renovation of 2no. Classrooms (50 students per classroom) to completion Tiling and painting	New Project	200,000.00

Sggy

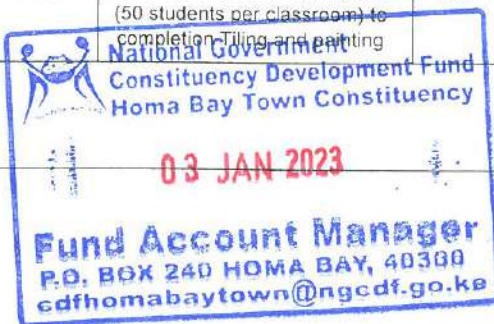

National Government Constituencies Development Fund

Fourth Schedule Report

Akele Primary School	4-0043-249-2630204-104-2022-2023-7	Renovation of 2no. Classrooms (50 students per classroom) Tiling, painting and electrical installation	New Project	400,000.00
Maguti Primary School	4-0043-249-2630204-104-2022-2023-8	Completion of 2no. Classrooms (50 students per classroom) Tiling and painting	Ongoing Project	509,960.00
Kuja Primary School	4-0043-249-2630204-104-2022-2023-9	Completion of 2No. Classrooms Tiling, Glazing and Painting	Ongoing Project	586,900.00
Gogo Katuma Primary School	4-0043-249-2630204-104-2022-2023-10	Completion of 2No. Classrooms (50 students per classroom) painting internally and externally	Ongoing Project	31,294.00
Yao Primary School	4-0043-249-2630204-104-2022-2023-11	Completion of 2No. Classrooms (50 students per classroom) electrical installation and painting internally and externally	Ongoing Project	178,680.00
Magare Primary School	4-0043-249-2630204-104-2022-2023-12	Completion of an administration block consisting of 2 offices and a staffroom Roofing, fittings of windows and doors complete with glazing and iron mongery, plastering and painting and tiling to the floor and project branding	Ongoing Project	1,899,200.00
Radiro Primary School	4-0043-249-2630204-104-2022-2023-13	Completion of an administration block consisting of 3 offices and a staffroom Roofing, fittings of windows and doors complete with glazing and iron mongery, plastering and painting and tiling to the floor and project branding	Ongoing Project	1,701,570.00
Pala Masogo Primary School	4-0043-249-2630204-104-2022-2023-14	Completion of an administration block consisting of 2 offices and a staffroom Roofing, fittings of windows and doors complete with glazing and iron mongery, plastering and painting and tiling to the floor and project branding	Ongoing Project	1,874,050.00
Sinangi Primary School	4-0043-249-2630204-104-2022-2023-15	Completion of 2 No. Classrooms (50 students per classroom) glazing of the windows plastering and painting and tiling to the floor and project branding	Ongoing Project	651,690.00
Nyauu Primary School	4-0043-249-2630204-104-2022-2023-16	Renovation to completion of 8no. Classrooms (50 students per classroom) Reroofing 2No. Classrooms, tiling, painting and glazing of 8No. Classrooms to completion	New Project	2,000,000.00
Nyakune Primary School	4-0043-249-2630204-104-2022-2023-17	Renovation to completion of 3no. Classrooms (50 students per classroom) Plastering, painting, tiling and glazing to the three classrooms to completion	New Project	800,000.00
Nyanguu Primary School	4-0043-249-2630204-104-2022-2023-18	Construction of administration block consisting of two offices and a staffroom to roofing level	New Project	1,900,000.00



 National Government Constituency Development Fund

 Homa Bay Town Constituency

 03 JAN 2023

 Fund Account Manager

 P.O. BOX 240 HOMA BAY, 40000

 cdfhomabaytown@ngdf.or.ke

National Government Constituencies Development Fund
Fourth Schedule Report

Sinangi Primary School	4-0043-249-2630204-104-2022-2023-19	Construction to completion of 4 door latrine (with 2 doors reserved for PWDs) to completion	New Project	800,000.00
Opande Primary School	4-0043-249-2630204-104-2022-2023-20	Construction to completion of 2No. Classrooms (50 students per classroom)	New Project	2,000,000.00
Wobiero Primary School	4-0043-249-2630204-104-2022-2023-21	Renovation to completion of 5 No. classrooms (50 students per classroom) Reroofing of 3 No. Classrooms, construction of the verandah area, tiling, painting and glazing to 5 No. Classrooms	New Project	1,400,000.00
Ndiru Primary School	4-0043-249-2630204-104-2022-2023-22	Completion of administration block consisting of a staffroom and 4 offices (Painting of the walls internally and externally and tiling) at kshs.1,100,000 and Renovation of 2No. Classrooms to completion (tiling, plastering and painting) at Kshs 400,000	New Project	1,500,000.00
Roba Primary School	4-0043-249-2630204-104-2022-2023-23	Construction to completion of 2 No. Classrooms (50 students per classroom)	New Project	2,000,000.00
Sinangi Primary School	4-0043-249-2630204-104-2022-2023-24	Construction to completion of 2No. Classrooms (50 students per classroom)	New Project	2,239,233.38
Achiero Primary School	4-0043-249-2630204-104-2022-2023-25	Construction to completion of 2 No classrooms at Kshs.2,279,017 and equipping with 50 desks at Kshs. 250,000 construction of a 4-door pit latrine (with 2 doors for PWDs) at Kshs. 790,083 and fencing of the school compound 3 acres with concrete poles and six strands of barbed wire and chain link at Kshs. 1,480,900	New Project	4,800,000.00
TOTAL:				33,895,482.38

Person completing form

SIGNATURE: _____

DATE: _____

NAME: _____

POSITION: _____



**FOURTH SCHEDULE (s. 30)
PROJECT DESCRIPTION FORM**

Constituency No 249
 Constituency Name HOMA BAY TOWN County Homa Bay
 Project Number 2630205
 Project Title Secondary School Projects
 Sector Education

Status of projects

Brief statement on project status at time of submission

Financial year 2022-07-01 to 2023-07-31
 Original Cost Estimates, in Ksh 36,650,000.00 dated
 Amount allocated last financial year dated

Sub projects

Project Name	Project Code	Activity	Original Status	Amount (Ksh)
Bishop Okulu Magare Girls school	4-0043-249-2630205-104-2022-2023-1	Completion of 2 classrooms (50 students per classroom) Plastering and painting	Ongoing Project	300,000.00
Wobiero Secondary School	4-0043-249-2630205-104-2022-2023-2	Completion of a Laboratory of 45 students capacity painting and gas installation	Ongoing Project	500,000.00
Chiga Mixed Secondary School	4-0043-249-2630205-104-2022-2023-3	Completion of 200 students capacity library Glazing of the windows, Plastering and painting of the walls and project branding	Ongoing Project	900,000.00
St. Camillus Ojunge Mixed Sec School	4-0043-249-2630205-104-2022-2023-4	Completion of 60 students capacity Laboratory General laboratory fittings, fittings of windows and doors, painting and project branding.	Ongoing Project	1,000,000.00
St Dominic Wiga Mixed Secondary School	4-0043-249-2630205-104-2022-2023-5	Completion of 2 No. Classrooms(50 students per classroom) plastering, Fittings of windows and doors complete with glazing, painting ,floor screed with smooth finish and project branding	Ongoing Project	250,000.00
Ogande Girls High School	4-0043-249-2630205-104-2022-2023-6	Additional funds for construction of modern library (Dr. Ida Odinga Library Research Innovation and Finance	Ongoing Project	10,000,000.00

[Handwritten signature]

**National Government Constituency Development Fund
Homa Bay Town Constituency**
 03 JAN 2023
Fund Account Manager
 P.O. BOX 240 HOMA BAY, 40300
 cdhombabaytown@ngcdf.go.ke

National Government Constituencies Development Fund
Fourth Schedule Report

		Centre) fittings, fixtures and finishes of the library wing and reinforced concrete superstructure of the entrance canopy, finishes of the flat roof and finishes of the columns with marine board		
St.Marys Marindi Girls Secondary School	4-0043-249-2630205-104-2022-2023-7	Purchase of 51-seater school bus (Isuzu FRR 33L, 51-Seater semi luxury institution bus with diesel propelled engine	Ongoing Project	8,700,000.00
St Pius Ndiru Secondary School	4-0043-249-2630205-104-2022-2023-8	Completion of 60 students capacity laboratory Fittings of windows and doors and plastering of the walls, Tiling of the floor, electrical installation and laboratory fittings.	Ongoing Project	1,500,000.00
St, Therasas Nyauu Girls Secondary School	4-0043-249-2630205-104-2022-2023-9	Construction of a 50 students capacity dormitory to completion	New Project	3,500,000.00
Nyakahia Mixed Secondary School	4-0043-249-2630205-104-2022-2023-10	Construction of 50 students capacity Library Substructure works, Reinforced Concrete Superstructure, Walling, roofing, fittings of windows and doors	New Project	3,000,000.00
St Peters Disii Mixed Secondary School	4-0043-249-2630205-104-2022-2023-11	Construction to completion of 4 No. Classrooms (using terrazzo floor) The school is located in an area with poor topography hence the high cost of project	New Project	5,000,000.00
Got Kokech Mixed Secondary School	4-0043-249-2630205-104-2022-2023-12	Construction to completion of 2No. Classrooms	New Project	2,000,000.00
TOTAL:				36,650,000.00

Person completing form

SIGNATURE: 

DATE: 10 / 1 / 23

NAME: William Oluo

POSITION: Form



FOURTH SCHEDULE (s. 30) PROJECT DESCRIPTION FORM

Constituency No 249

Constituency Name HOMA BAY TOWN County Homa Bay

Project Number 2640507

Project Title Security Projects

Sector Security

Status of projects

Brief statement on project status at time of submission

Financial year 2022-07-01 to 2023-07-31

Original Cost Estimates, in Ksh 3,750,000.00 dated

Amount allocated last financial year dated

Sub projects

Project Name	Project Code	Activity	Original Status	Amount (Ksh)
East Kanyada Location Chiefs Office	4-0043-249-2640507-113-2022-2023-1	Completion of chiefs office consisting of 2 offices, conference and waiting bay Superstructure works, roofing, fittings and plastering, painting, electrical works and project branding.	Ongoing Project	1,250,000.00
Kanyach Kachar Location Chiefs Office	4-0043-249-2640507-113-2022-2023-2	Completion of chiefs office consisting of 2 offices, conference and waiting bay Superstructure works, roofing, fittings and plastering, painting, electrical works and project branding	Ongoing Project	1,250,000.00
Komollo Location Chiefs Office	4-0043-249-2640507-113-2022-2023-3	Completion of chiefs office consisting of 2 offices, conference and waiting bay Superstructure works, roofing, fittings and plastering, painting, electrical works and project branding	Ongoing Project	1,250,000.00
			TOTAL:	3,750,000.00

Person completing form



National Government Constituencies Development Fund
Fourth Schedule Report

SIGNATURE:  DATE: 10 / 1 / 23
NAME: Wilson Okumu POSITION: FAN



FOURTH SCHEDULE (s. 30)
PROJECT DESCRIPTION FORM

Constituency No 249
Constituency Name HOMA BAY TOWN County Homa Bay
Project Number 2640509
Project Title Sports Activities
Sector Sports

Status of projects

Brief statement on project status at time of submission

Financial year 2022-07-01 to 2023-07-31
Original Cost Estimates, in Ksh 2,464,300.66 dated
Amount allocated last financial year dated

Sub projects

Project Name	Project Code	Activity	Original Status	Amount (Ksh)
Constituency Sports Tournament	4-0043-249-2640509-112-2022-2023-1	Organizing sport tournaments whereby the winning teams will be awarded with balls, nets, games kits and trophies	New Project	2,114,300.66
Regional Sports Tournament	4-0043-249-2640509-112-2022-2023-2	Facilitate regional sports tournament in partnership with other Constituencies within the Region.	New Project	350,000.00
			TOTAL:	2,464,300.66

Person completing form

SIGNATURE:



DATE:

11/1/23

NAME:

WILSON OREN

POSITION:

Team Manager



FOURTH SCHEDULE (s. 30) PROJECT DESCRIPTION FORM

Constituency No 249
Constituency Name HOMA BAY TOWN County Homa Bay
Project Number 2640510
Project Title Environmental Projects
Sector Environment

Status of projects

Brief statement on project status at time of submission

Financial year 2022-07-01 to 2023-07-31
Original Cost Estimates, in Ksh 914,300.00 dated
Amount allocated last financial year dated

Sub projects

Project Name	Project Code	Activity	Original Status	Amount (Ksh)
Otaro Primary School	4-0043-249-2640510-110-2022-2023-1	Landscaping of 1.5 acres school compound (rough grades, drainage, hardscapes, Finish grades) to completion	New Project	914,300.00
TOTAL:				914,300.00

Person completing form

SIGNATURE: _____

DATE: _____

NAME: _____

POSITION: _____



**FOURTH SCHEDULE (s. 30)
PROJECT DESCRIPTION FORM**

Constituency No 249
 Constituency Name HOMA BAY TOWN County Homa Bay
 Project Number 3110202
 Project Title CDFC offices
 Sector ACQUISITION OF ASSETS

Status of projects

Brief statement on project status at time of submission

Financial year 2022-07-01 to 2023-07-31
 Original Cost Estimates, in Ksh 1,883,306.66 dated
 Amount allocated last financial year dated

Sub projects

Project Name	Project Code	Activity	Original Status	Amount (Ksh)
NG-CDF Office	4-0043-249-3110202-310-2022-2023-1	Renovation of NG-CDF Office modification of office to create 2 internal flush toilets (in the Fund Account Managers Office and chairpersons office), plumbing works and guttering at Kshs.1,883,156.66 and purchase and installation of 10,000 litres water tank at Kshs.150,000	New Project	1,883,306.66
			TOTAL:	1,883,306.66

Person completing form

SIGNATURE: _____

DATE: _____

NAME: _____

POSITION: _____



FOURTH SCHEDULE (s. 30)
PROJECT DESCRIPTION FORM

Constituency No 249
Constituency Name HOMA BAY TOWN County Homa Bay
Project Number 2211310
Project Title Contracted Professional Services - e.g Strategic Planning
Sector Others

Status of projects

Brief statement on project status at time of submission

Financial year 2022-07-01 to 2023-07-31

Original Cost Estimates, in Ksh 2,000,000.00 dated

Amount allocated last financial year dated

Sub projects

Project Name	Project Code	Activity	Original Status	Amount (Ksh)
Homa Bay Town NG-CDF Strategic plan	4-0043-249-2211310-108-2022-2023-1	To facilitate development of 5-year constituency strategic plan	New Project	2,000,000.00
			TOTAL:	2,000,000.00

Person completing form

SIGNATURE: 

DATE: 10 / 1 / 23

NAME: Wilson Okumu

POSITION: FAW



FOURTH SCHEDULE (s. 30) PROJECT DESCRIPTION FORM

Constituency No 249
Constituency Name HOMA BAY TOWN County Homa Bay
Project Number 2210401
Project Title Travel Costs (airlines, bus, railway, etc.)
Sector Constituency Oversight

Status of projects

Brief statement on project status at time of submission

Financial year 2022-07-01 to 2023-07-31

Original Cost Estimates, in Ksh 192,000.00 dated

Amount allocated last financial year dated

Sub projects

Project Name	Project Code	Activity	Original Status	Amount (Ksh)
Travel Costs	4-0043-249-2210401-114-2022-2023-1	Payment of the Constituency Oversight Committee Travel Costs (Airlines, Bus, Railway)	New Project	192,000.00
			TOTAL:	192,000.00

Person completing form

SIGNATURE: [Signature] DATE: 10 / 1 / 23
NAME: Wilson Oluo POSITION: FAM



FOURTH SCHEDULE (s. 30) PROJECT DESCRIPTION FORM

Constituency No 249

Constituency Name HOMA BAY TOWN County Homa Bay

Project Number 2210402

Project Title Accommodation

Sector Constituency Oversight

Status of projects

Brief statement on project status at time of submission

Financial year 2022-07-01 to 2023-07-31

Original Cost Estimates, in Ksh 240,000.00 dated

Amount allocated last financial year dated

Sub projects

Project Name	Project Code	Activity	Original Status	Amount (Ksh)
Accommodation - Domestic Travel	4-0043-249-2210402-114-2022-2023-10	Payment of the Constituency Oversight Committee Domestic Travel accommodation expenses	New Project	240,000.00
TOTAL:				240,000.00

Person completing form

SIGNATURE:  DATE: 08 / 01 / 2023

NAME: Wilson Okumu POSITION: FAM

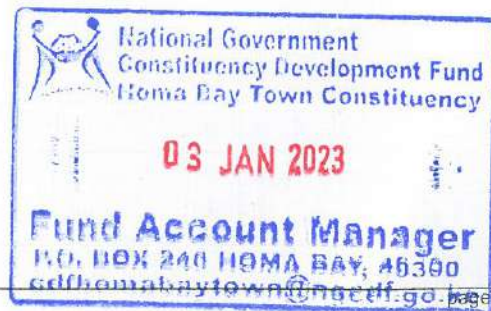

FOURTH SCHEDULE (s. 30) PROJECT DESCRIPTION FORM

Constituency No 249
Constituency Name HOMA BAY TOWN County Homa Bay
Project Number 2210303
Project Title Daily Subsistence Payment of Daily Subsistence Allowance
Sector Constituency Oversight

Status of projects

Brief statement on project status at time of submission

Financial year 2022-07-01 to 2023-07-31
Original Cost Estimates, in Ksh 192,000.00 dated
Amount allocated last financial year dated

Sub projects

Project Name	Project Code	Activity	Original Status	Amount (Ksh)
Daily Subsistence Allowance	4-0043-249-2210303-114-2022-2023-5	Payment of the Constituency Oversight Committee daily subsistence allowances	New Project	192,000.00
TOTAL:				192,000.00

Person completing form

SIGNATURE:

[Handwritten Signature]
Wilson Okumu

DATE:

03 / 01 / 2023

NAME:

POSITION:

FAM



FOURTH SCHEDULE (s. 30) PROJECT DESCRIPTION FORM

Constituency No 249

Constituency Name HOMA BAY TOWN County Homa Bay

Project Number 2210802

Project Title Committee Expenses

Sector Constituency Oversight

Status of projects

Brief statement on project status at time of submission

Financial year 2022-07-01 to 2023-07-31

Original Cost Estimates, in Ksh 240,000.00 dated

Amount allocated last financial year dated

Sub projects

Project Name	Project Code	Activity	Original Status	Amount (Ksh)
Constituency Oversight Committee Members Allowance	4-0043-249-2210802-114-2022-2023-22	Payment of the Constituency Oversight Committee allowances	New Project	240,000.00
TOTAL:				240,000.00

Person completing form

SIGNATURE:  DATE: 03 / 01 / 2023

NAME: Wilton Okumu POSITION: FAM



**FOURTH SCHEDULE (s. 30)
PROJECT DESCRIPTION FORM**

Constituency No 249

Constituency Name HOMA BAY TOWN County Homa Bay

Project Number 2211201

Project Title Refined Fuels and Lubricants for Transport

Sector Constituency Oversight

Status of projects

Brief statement on project status at time of submission

Financial year 2022-07-01 to 2023-07-31

Original Cost Estimates, in Ksh 96,000.00 dated

Amount allocated last financial year dated

Sub projects

Project Name	Project Code	Activity	Original Status	Amount (Ksh)
Refined Fuels and Lubricants for Transport	4-0043-249-2211201-114-2022-2023-20	To cater for Refined Fuels and Lubricants for Transport during Constituency Oversight Committee activities	New Project	96,000.00
			TOTAL:	96,000.00

Person completing form

SIGNATURE: *Wilson Okumu* DATE: 03 / 01 / 2023

NAME: Wilson Okumu POSITION: FAM





REPUBLIC OF KENYA



NATIONAL GOVERNMENT CONSTITUENCY DEVELOPMENT FUND
HOMA BAY TOWN CONSTITUENCY

ENGINEERS ESTIMATE

FOR

THE PROPOSED CONSTRUCTION OF AN ADMINISTRATION
BLOCK

AT

NYANGUU PRIMARY SCHOOL

IN

HOMA BAY TOWN CONSTITUENCY

PREPARED BY:

CLERK OF WORKS,

P.O BOX 240-40300,

HOMA BAY TOWN CONSTITUENCY

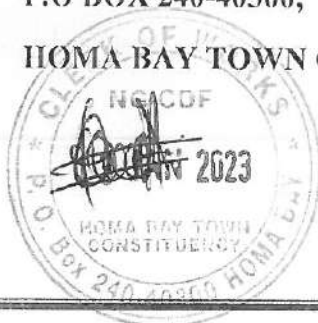

APPROVED BY:

SUB-COUNTY WORKS OFFICER

P.O BOX 89-40300

HOMABAY

SUB-COUNTY WORKS OFFICER
HOMA BAY COUNTY
P. O. Box 89-40300,
HOMA BAY

PROPOSED CONSTRUCTION OF AN ADMINISTRATION BLOCK NYANGUU PRIMARY SCHOOL

SUMMARY

ITEM	DESCRIPTION	AMOUNT (KSHS/CTS)
I	SUBSTRUCTURE CARRIED FROM PAGE 3	1,219,570.00
II	SUPERSTRUCTURE CARRIED FROM PAGE 4	248,150.00
III	WALLING CARRIED FROM PAGE 5	368,000.00
IV	WINDOWS CARRIED FROM PAGE 6	109,650.00
V	DOORS CARRIED FROM PAGE 7	75,150.00
VI	ROOFING CARRIED FROM PAGE 9	601,600.00
VII	FINISHES CARRIED FROM PAGE 10	533,300.00
	TOTAL FOR MEASURED WORKS CARRIED TO GRAND SUMMARY	3,155,420.00

PROPOSED CONSTRUCTION OF AN ADMINISTRATION BLOCK NYANGUU PRIMARY SCHOOL

ITEM	DESCRIPTION	QTY	UNIT	RATE	AMOUNT (KSHS/CTS)
	<u>Floor Finishes</u>				
A	32mm thick cement and sand (1:4) screed beds complete with and including 'Superbond Tile Adhesive' or other equal and approved adhesive mixed to manufacturers' instructions; prepared to receive ceramic floor tiles.	130	SM	350	45,500.00
B	Take delivery and fix 300mm x 300mm x 10mm thick approved coloured non-slip ceramic floor tiles laid on cement and sand screed (m.s) and including bedding and jointing with cement grout, pointing in stained cement and laying to falls where necessary.	130	SM	1,400	182,000.00
C	100mm x 25mm high ceramic tiles skirting.	93	LM	300	28,200.00
CARRIED TO COLLECTION					255,700.00
<u>COLLECTION</u>					
	BROUGHT FORWARD FROM PAGE 10				277,600.00
	BROUGHT DOWN FROM ABOVE				255,700.00
TOTAL FOR FINISHES CARRIED TO SUMMARY					533,300.00

PROPOSED CONSTRUCTION OF AN ADMINISTRATION BLOCK NYANGUU PRIMARY SCHOOL

GRAND SUMMARY		
ITEM	DESCRIPTION	AMOUNT (KSHS/CTS)
I	MEASURED WORKS	3,155,420.00
II	PRIME COST SUMS	170,000.00
	SUB-TOTAL I	3,325,420.00
III	ADD FOR PROJECT MANAGEMENT COMMITTEE COST	104,580.00
IV	ADD PROJECT MANAGEMENT AND ADMINISTRATION FEES BY PROJECT MANAGER	70,000.00
	GRAND SUMMARY	3,500,000.00

AMOUNT IN WORDS KENYA SHILLINGS THREE MILLION FIVE HUNDRED THOUSAND SHILLINGS ONLY

PREPARED BY :
NAME: OLIVER AKINYI
DESIGNATION: NO-CDF

SIGNATURE:  2023

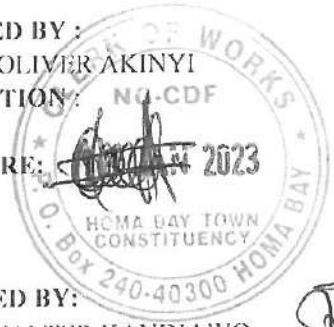

APPROVED BY:
NAME: WALTER KANDIAWO
DESIGNATION :

SIGNATURE:

COUNTY WORKS OFFICER
HOMA BAY COUNTY
P. O. Box 89-40300
HOMA BAY

ALL RATES ARE INCLUSIVE OF 16% V.A.T

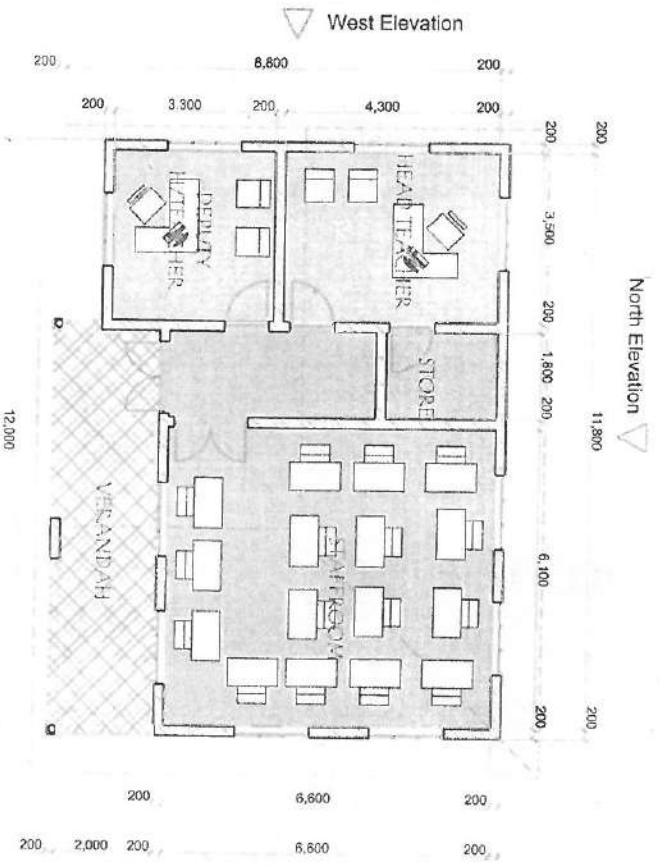

GROUND FLOOR PLAN

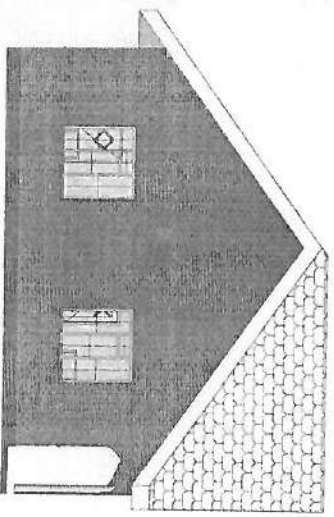

WEST ELEVATION

East Elevation

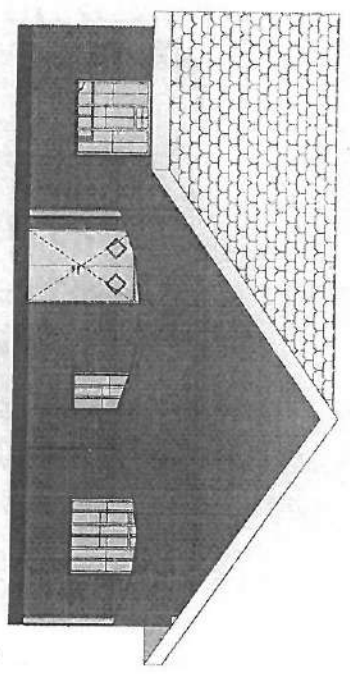

SOUTH ELEVATION

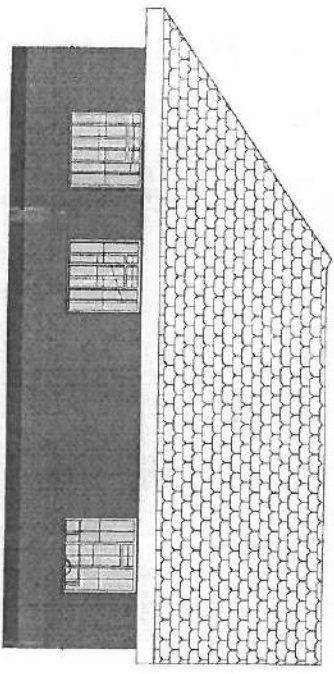

NORTH ELEVATION



COUNTY WORKS OFFICER
 HOMA BAY COUNTY
 P. O. Box 89-40996
 HOMA BAY



REPUBLIC OF KENYA



**NATIONAL GOVERNMENT CONSTITUENCY DEVELOPMENT FUND
HOMA BAY TOWN CONSTITUENCY**

**ENGINEERS ESTIMATE
FOR**

**THE PROPOSED FENCING AND GATE INSTALLATION
AT**

**OTARO PRIMARY SCHOOL
IN**

HOMA BAY TOWN CONSTITUENCY

PREPARED BY:

CLERK OF WORKS,

P.O BOX 240-40300,

HOMA BAY TOWN CONSTITUENCY



APPROVED BY:

SUB-COUNTY WORKS OFFICER

P.O BOX 89-40300

HOMABAY

**COUNTY WORKS OFFICER
HOMA BAY COUNTY
P. O. Box 89-40300,
HOMA BAY**

PROPOSED FENCING AND GATE INSTALLATION AT OTARO PRIMARY SCHOOL

M	DESCRIPTION	QTY	UNIT	RATE	AMOUNT (KSHS/CTS)
A	<p><u>GATE</u></p> <p>Supply and fix 8000x2400mm High double leaf gate on No. 300X300X3000mm high concrete columns. The gate is comprising of 2 No. 2600X2400mm high equal openable leaves built with 50X50mm RIIIS stiles, top and bottom rails infilled with 8x25mm mild steel flats and 25X 25mm RIIIS members all welded to form pattern on each leaf complete with 50 x50mm RHS frame, 6 No pin hinges complete with all associated iron mongery and painting to the clients approval . complete with wingwalls</p>	1	NO	100,000	100,000.00
	CARRIED TO COLLECTION				100,000.00
	<p>COLLECTION</p> <p>BROUGHT FORWARD FROM PAGE 1</p> <p>BROUGHT DOWN FROM ABOVE</p>				<p>1,182,500.00</p> <p>100,000.00</p>
	<p>TOTAL FOR FENCING AND GATE INSTALLATION CARRIED TO GRAND SUMMARY</p>				1,282,500.00

PROPOSED FENCING AND GATE INSTALLATION AT OTARO PRIMARY SCHOOL

ITEM	DESCRIPTION	AMOUNT (KSHS/CTS)
I	FENCING AND GATE INSTALLATION	1,282,500.00
	SUB-TOTAL I	1,282,500.00
III	ADD PROJECT MANAGEMENT COMMITTEE COST	40,500.00
IV	ADD PROJECT MANAGEMENT AND ADMINISTRATION FEES BY PROJECT	27,000.00
	GRAND SUMMARY FOR FENCING , GATE INSTALLATION AND LANDSCAPPING	1,350,000.00
	KSH.	

AMOUNT IN WORDS : ONE MILLION THREE HUNDRED AND FIFTY THOUSAND SHILLINGS ONLY

PREPARED BY :

NAME: OLIVER AKINYI
DESIGNATION : CLERK OF WORKS

SIGNATURE: 

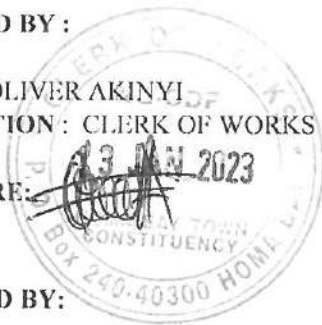

APPROVED BY:

NAME: WALTER KANDIAWO
DESIGNATION : SUB COUNTY WORKS OFFICER

SIGNATURE: 

ALL RATES ARE INCLUSIVE OF 16% V.A.T



REPUBLIC OF KENYA



NATIONAL GOVERNMENT CONSTITUENCY DEVELOPMENT FUND
HOMA BAY TOWN CONSTITUENCY

ENGINEERS ESTIMATE

FOR

THE PROPOSED RENOVATION OF 2 NO. CLASSROOMS

AT

AKELE PRIMARY SCHOOL

IN

HOMA BAY TOWN CONSTITUENCY

PREPARED BY:

CLERK OF WORKS,

P.O BOX 240-40300,

HOMA BAY TOWN CONSTITUENCY



APPROVED BY:

SUB-COUNTY WORKS OFFICER

P.O BOX 89-40300

HOMABAY

SUB-COUNTY WORKS OFFICER
HOMA BAY COUNTY
P. O. Box 89-40300,
HOMA BAY

PROPOSED RENOVATION OF 2NO. CLASSROOMS AT AKELE PRIMARY SCHOOL

<u>SUMMARY</u>		
<u>ITEM</u>	<u>DESCRIPTION</u>	<u>AMOUNT (KSHS/CTS)</u>
1	FINISHES CARRIED FROM PAGE 3	317,150.00
	TOTAL FOR BUILDER'S WORK CARRIED TO GRAND SUMMARY	317,150.00

PROPOSED RENOVATION OF 2NO. CLASSROOMS AT AKELE PRIMARY SCHOOL

ITEM	DESCRIPTION	AMOUNT (KSHS/CTS)
	<u>PRIME COST SUMS</u>	
	<u>Sign Board</u>	
A	Allow a provisional sum of Kenya Shilling Twenty Thousand for erection of a sign board and branding of Project in accordance with NG-CDF Board Specifications	20,000.00
	<u>ELECTRICAL INSTALLATION</u>	
B	Allow a provisional sum of Kenya Shilling Twenty Five Thousand for electrical works	25,000.00
	TOTAL FOR PRIME COST SUMS CARRIED TO GRAND SUMMARY	45,000.00

PROPOSED RENOVATION OF 2NO. CLASSROOMS AT AKELE PRIMARY SCHOOL

ITEM	DESCRIPTION	AMOUNT (KSHS/CTS)
	<u>GRAND SUMMARY</u>	
I	BUILDER'S WORK	317,150.00
II	PRIME COST SUM	45,000.00
	SUB-TOTAL I	362,150.00
III	ADD PROJECT MANAGEMENT COMMITTEE COST	22,850.00
IV	ADD PROJECT MANAGEMENT AND ADMINISTRATION FEES BY PROJECT MANAGER	15,000.00
	SUB-TOTAL II	
	GRAND SUMMARY	400,000.00
	KSH.	

AMOUNT IN WORDS : FOUR HUNDRED THOUSAND SHILLINGS ONLY.

PREPARED BY :

NAME: OLIVER AKINYI

DESIGNATION : CLERK OF WORKS

SIGNATURE:



APPROVED BY:

NAME: WALTER KANDIAWO

DESIGNATION : SUB COUNTY WORKS OFFICER

SIGNATURE:

COUNTY WORKS OFFICER
HOMA BAY COUNTY
 P. O. Box 89-40300,
 HOMA BAY

ALL RATES ARE INCLUSIVE OF 16% V.A.T



NATIONAL GOVERNMENT CONSTITUENCIES DEVELOPMENT FUND
HOMABAY TOWN CONSTITUENCY
Kabunde Multipurpose Hall
P.O BOX 240 Homabay, 40300
Email: cdfhomabaytown@ngcdf.go.ke | Website: www.ngcdf.go.ke

TO:

**THE PROGRAMMES AND FIELD SERVICES CO-ORDINATION DEPARTMENT
NATIONAL GOVERNMENT CONSTITUENCIES DEVELOPMENT FUND BOARD**

RE: PROPOSED RENOVATION OF 2 NO. CLASSROOMS IN AKELE PRIMARY SCHOOL

The Homabay Town Constituency Committee convened a ward meeting for public participation as per the National Government Constituencies Development Fund Act 2015 section 27(1) to generate projects given priority in the constituency. Akele Primary School is located in Homabay West Ward and was identified as one of the schools to be given priority.

Site investigation was done by the technical team and it was noticed that 2 No. Classrooms needed renovation. The following elements were identified:

- **Floor finish:** The floors were in bad conditions and there was need to scrap off the existing floor screed in some areas and be replaced with tilling done with non-slip ceramic floor tiles both internally and on the verandahs.
- **Painting:** The paints on the walls are worn out and therefore the walls need new painting which is to be done with three coats of silk emulsion paint.
- **Electrical Installation :** The two classrooms had incomplete electrical works and there's danger since the wires are naked and are in areas reachable by the students, therefore there's need for correction.

The attached Bills of Quantities gives the breakdown of the costs with the grand total at Kshs 200,000

Yours Faithfully,

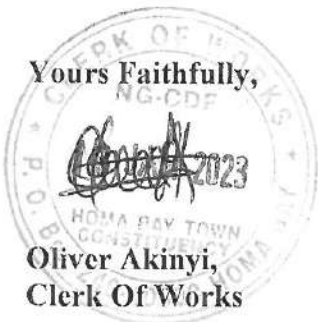

**Oliver Akinyi,
Clerk Of Works**

Confirmed by ;

COUNTY WORKS OFFICER
HOMA BAY COUNTY
P. O. Box 89-40300,
HOMA BAY

Walter Kandiawo
Sub County Works Officer



REPUBLIC OF KENYA



NATIONAL GOVERNMENT CONSTITUENCY DEVELOPMENT FUND
HOMA BAY TOWN CONSTITUENCY

ENGINEERS ESTIMATE

FOR

THE PROPOSED RENOVATION OF 2 NO. CLASSROOMS

AT

NDORI PRIMARY SCHOOL

IN

HOMA BAY TOWN CONSTITUENCY

PREPARED BY:

CLERK OF WORKS,

P.O BOX 240-40300,

HOMA BAY TOWN CONSTITUENCY



APPROVED BY:

SUB-COUNTY WORKS OFFICER

P.O BOX 89-40300

HOMABAY

SUB-COUNTY WORKS OFFICER
HOMA BAY COUNTY
P. O. Box 89-40300,
HOMA BAY

PROPOSED RENOVATION OF 2NO. CLASSROOMS AT NDORI PRIMARY SCHOOL

<u>SUMMARY</u>		
<u>ITEM</u>	<u>DESCRIPTION</u>	<u>AMOUNT (KSHS/CTS)</u>
I	FINISHES CARRIED FROM PAGE 3	169,992.00
TOTAL FOR BUILDER'S WORK CARRIED TO GRAND SUMMARY		169,992.00

PROPOSED RENOVATION OF 2NO. CLASSROOMS AT NDORI PRIMARY SCHOOL

ITEM	DESCRIPTION	AMOUNT (KSHS/CTS)
A	<p style="text-align: center;"><u>PRIME COST SUMS</u></p> <p><u>Sign Board</u></p> <p>Allow a provisional sum of Kenya Shilling Twenty Thousand for erection of a sign board and branding of Project in accordance with NG-CDF Board Specifications</p>	20,000.00
	TOTAL FOR PRIME COST SUMS CARRIED TO GRAND SUMMARY	20,000.00

PROPOSED RENOVATION OF 2NO. CLASSROOMS AT NDORI PRIMARY SCHOOL

ITEM	DESCRIPTION	AMOUNT (KSHS/CTS)
<u>GRAND SUMMARY</u>		
I	BUILDER'S WORK	169,992.00
II	PRIME COST SUM	20,000.00
SUB-TOTAL I		189,992.00
III	ADD PROJECT MANAGEMENT COMMITTEE COST	6,008.00
IV	ADD PROJECT MANAGEMENT AND ADMINISTRATION FEES BY PROJECT MANAGER	4,000.00
SUB-TOTAL II		
GRAND SUMMARY		200,000.00
	KSH.	

AMOUNT IN WORDS : TWO HUNDRED THOUSAND SHILLINGS ONLY.

PREPARED BY :
 NAME: OLIVER AKINYI
 DESIGNATION : CLERK OF WORKS

SIGNATURE: 

APPROVED BY:
 NAME: WALTER KANDIAWO
 DESIGNATION : SUB COUNTY WORKS OFFICER

SIGNATURE:

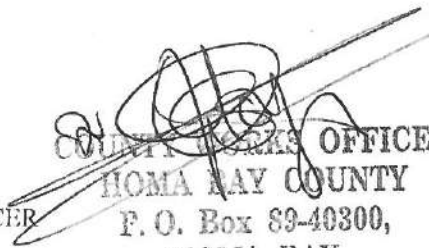
 COUNTY WORKS OFFICER
 HOMA BAY COUNTY
 P. O. Box 89-40300,
 HOMA BAY

ALL RATES ARE INCLUSIVE OF 16% V.A.T

NG-CDF BOARD

TO:

**THE PROGRAMMES AND FIELD SERVICES CO-ORDINATION DEPARTMENT
NATIONAL GOVERNMENT CONSTITUENCIES DEVELOPMENT FUND BOARD**

RE: PROPOSED RENOVATION OF 2 NO. CLASSROOMS IN NDORI PRIMARY SCHOOL

The Homabay Town Constituency Committee convened a ward meeting for public participation as per the National Government Constituencies Development Fund Act 2015 section 27(1) to generate projects given priority in the constituency. Ndori Primary School is located in Homabay East Ward and was identified as one of the schools to be given priority.

Site investigation was done by the technical team and it was noticed that 2 No. Classrooms needed renovation. The following elements were identified:

- **Floor finish:** The floors were in bad conditions and there was need to scrap off the existing floor screed in some areas and be replaced with tilling done with non-slip ceramic floor tiles both internally and on the verandahs.
- **Painting:** The paints on the walls are worn out and therefore the walls need new painting which is to be done with three coats of silk emulsion paint.

The attached Bills of Quantities gives the breakdown of the costs with the grand total at Kshs 200,000

Yours Faithfully,

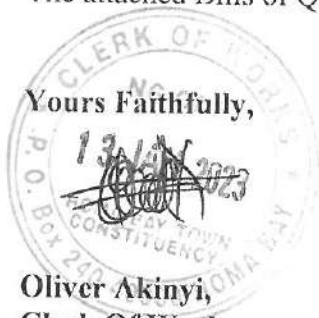

Oliver Akinyi,
Clerk Of Works

Confirmed by ;

COUNTY WORKS OFFICER
HOMA BAY COUNTY
P. O. Box 89-40300,
HOMA BAY

Walter Kandiawo
Sub County Works Officer



REPUBLIC OF KENYA



**NATIONAL GOVERNMENT CONSTITUENCY DEVELOPMENT FUND
HOMA BAY TOWN CONSTITUENCY**

**ENGINEERS ESTIMATE
FOR**

**THE PROPOSED COMPLETION OF AN ADMINISTRATION
BLOCK AND RENOVATION OF 2 NO. CLASSROOMS**

AT

NDIRU PRIMARY SCHOOL

IN

HOMA BAY TOWN CONSTITUENCY

PREPARED BY:

CLERK OF WORKS,

P.O BOX 240-40300,

HOMA BAY TOWN CONSTITUENCY

APPROVED BY:

SUB-COUNTY WORKS OFFICER

P.O BOX 89-40300

HOMABAY COUNTY WORKS OFFICER

HOMA BAY COUNTY

P. O. Box 89-40300,

HOMA BAY



SED COMPLETION OF ADMINISTRATION BLOCK AND RENOVATION OF 2 NO. CLASSROOMS AT
NDIRU PRIMARY SCHOOL

<u>SUMMARY</u>		
ITEM	DESCRIPTION	AMOUNT (KSHS/CTS)
I	WINDOWS CARRIED FROM PAGE 1	62,050.00
II	TOTAL CARRIED FROM PAGE 2	341,100.00
III	FINISHES CARRIED FROM PAGE 3	922,160.00
	TOTAL FOR BUILDER'S WORK CARRIED TO GRAND SUMMARY	1,325,310.00

**USED COMPLETION OF ADMINISTRATION BLOCK AND RENOVATION OF 2 NO. CLASSROOMS AT
NDIRU PRIMARY SCHOOL**

ITEM	DESCRIPTION	AMOUNT (KSHS/CTS)
<u>PRIME COST SUMS</u>		
<u>Sign Board</u>		
A	Allow a provisional sum of Kenya Shilling Twenty Thousand for erection of a sign board and branding of Project in accordance with NG-CDF Board Specifications	20,000.00
B	Allow a provisional sum of Kenya Shillings Thirty thousand for construction of ramp for access of people with disability in the classrooms	30,000.00
C	Allow a provisional sum of Kenya Shillings Fifty thousand for completion of electrical works	50,000.00
TOTAL FOR PRIME COST SUMS CARRIED TO GRAND SUMMARY		100,000.00

**PROPOSED COMPLETION OF ADMINISTRATION BLOCK AND RENOVATION OF 2 NO. CLASSROOMS AT
NDIRU PRIMARY SCHOOL**

ITEM	DESCRIPTION	AMOUNT (KSHS/CTS)
	<u>GRAND SUMMARY</u>	
I	BUILDER'S WORK	1,325,310.00
II	PRIME COST SUM	100,000.00
	SUB-TOTAL I	1,425,310.00
III	ADD PROJECT MANAGEMENT COMMITTEE COST	44,800.00
IV	ADD PROJECT MANAGEMENT AND ADMINISTRATION FEES BY PROJECT MANAGER	29,890.00
	SUB-TOTAL II	
	GRAND SUMMARY	1,500,000.00
	KSH.	

AMOUNT IN WORDS : ONE MILLION FIVE HUNDRED THOUSAND SHILLINGS ONLY.

PREPARED BY :
NAME: OLIVER AKINYI
DESIGNATION : CLERK OF WORKS

SIGNATURE:



APPROVED BY:
NAME: WALTER KANDIAWO
DESIGNATION : SUB COUNTY WORKS OFFICER

SIGNATURE:



**SUB COUNTY WORKS OFFICER
HOMA BAY COUNTY
P. O. Box 89-40300,
HOMA BAY**

ALL RATES ARE INCLUSIVE OF 16% V.A.T



NGCDF BOARD

NATIONAL GOVERNMENT CONSTITUENCIES DEVELOPMENT FUND
HOMABAY TOWN CONSTITUENCY
Kabunde Multipurpose Hall
P.O BOX 240 Homabay, 40300
Email: cdfhomabaytown@ngcdf.go.ke | Website: www.ngcdf.go.ke

TO:

**THE PROGRAMMES AND FIELD SERVICES CO-ORDINATION DEPARTMENT
NATIONAL GOVERNMENT CONSTITUENCIES DEVELOPMENT FUND BOARD**

RE: PROPOSED RENOVATION OF 2NO. CLASSROOMS IN NDIRU PRIMARY SCHOOL

The Homabay Town Constituency Committee convened a ward meeting for public participation as per the National Government Constituencies Development Fund Act 2015 section 27(1) to generate projects given priority in the constituency. Ndiru Primary School is located in Homabay East Ward and was identified as one of the schools to be given priority.

Site investigation was done by the technical team and it was noticed that 2No. Classrooms needed renovation. The following elements were identified:

- **Floor finish:** The floors were in bad conditions and there was need to scrap off the existing floor screed and be replaced with tilling done with non-slip ceramic floor tiles both internally and on the verandahs.
- **Plastering and Painting:** The walls had major and minor cracks which need to be plastered with cement and sand finished smooth in the internal and rendered on the external complete with painting with three coats of silk emulsion paint.

The attached Bills of Quantities gives the breakdown of the costs with the grand total at Kshs 400,000

Yours Faithfully,

Oliver Akinyi,
Clerk Of Works

Confirmed by ;

COUNTY WORKS OFFICER
HOMA BAY COUNTY
P. O. Box 89-40300,
HOMA BAY

Walter Kandiawo
Sub County Works Officer



REPUBLIC OF KENYA



NATIONAL GOVERNMENT CONSTITUENCY DEVELOPMENT FUND
HOMA BAY TOWN CONSTITUENCY

ENGINEERS ESTIMATE
FOR

THE PROPOSED CONSTRUCTION OF 2 NO. CLASSROOMS,
AT

OPANDE RARAGE PRIMARY SCHOOL
IN

HOMA BAY TOWN CONSTITUENCY

PREPARED BY:
CLERK OF WORKS,
P.O BOX 240-40300,
HOMA BAY TOWN CONSTITUENCY



APPROVED BY:
SUB-COUNTY WORKS OFFICER
P.O BOX 89-40300
HOMABAY

COUNTY WORKS OFFICER
HOMA BAY COUNTY
P. O. Box 89-40300,
HOMA BAY

PROPOSED CONSTRUCTION OF 2 NO. CLASSROOMS AT OPANDE RARAGE PRIMARY SCHOOL

ITEM	DESCRIPTION	AMOUNT (KSHS/CTS)
<u>PRIME COST SUMS</u>		
A	Allow a provisional sum of Kenya Shilling Twenty Thousand for erection of a sign board and branding of Project in accordance with NG-CDF Board Specifications	20,000.00
B	Allow a Prime Cost Sum of Kenya Shillings Seventy Thousand for execution of electrical works.	70,000.00
TOTAL FOR PRIME COST SUMS CARRIED TO GRAND SUMMARY		90,000.00

PROPOSED CONSTRUCTION OF 2 NO. CLASSROOMS AT OPANDE RARAGE PRIMARY SCHOOL

GRAND SUMMARY

ITEM	DESCRIPTION	AMOUNT (KSHS/CTS)
I	MEASURED WORKS	1,810,000.00
II	PRIME COST SUMS	90,000.00
	SUB-TOTAL I	1,900,000.00
III	ADD 3% FOR PROJECT MANAGEMENT COMMITTEE COST	60,000.00
III	ADD 2% FOR PROJECT MANAGEMENT	40,000.00
	GRAND SUMMARY FOR 2 NO. CLASSROOMS	2,000,000.00

AMOUNT IN WORDS : TWO MILLION SHILLINGS ONLY

PREPARED BY :

NAME: OLIVER AKINYI
 DESIGNATION : CIVIL WORKS

SIGNATURE:



APPROVED BY:

NAME: WALTER KANDIAWO
 DESIGNATION : SUB COUNTY WORKS OFFICER

SIGNATURE:

COUNTY WORKS OFFICER
 HOMA BAY COUNTY
 P. O. Box 89-40300,
 HOMA BAY

ALL RATES ARE INCLUSIVE OF 16% V.A.T

REAR ELEVATION

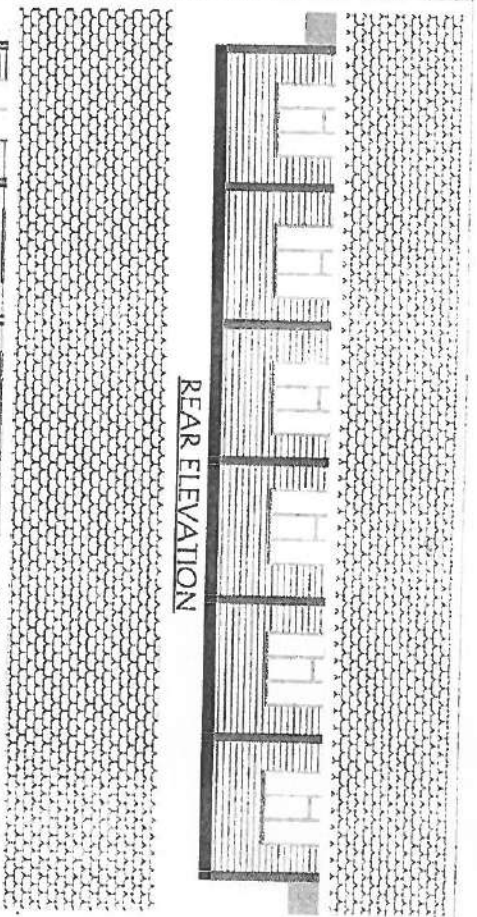

FRONT ELEVATION

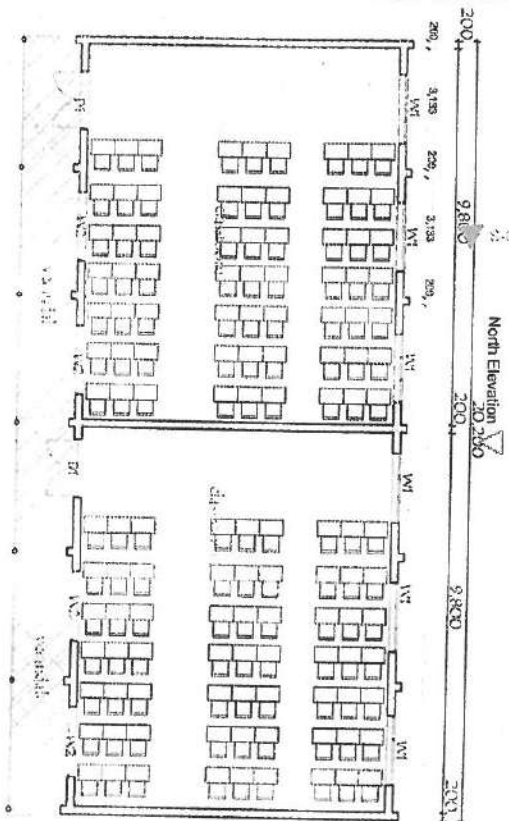

GROUND FLOOR PLAN

SIDE ELEVATION

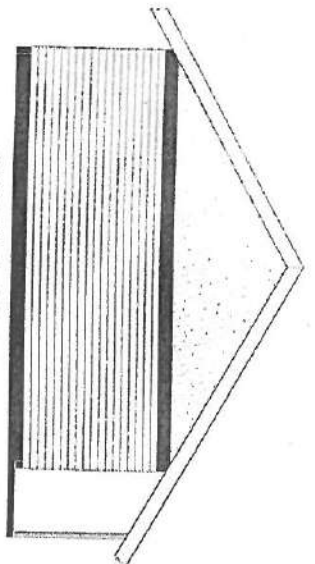

SECTION ELEVATION

19mm thick plaster
150mm corr fl slab
hvc mesh class A142
500x25mm
100mm masonry blinding
200mm hardcore filling
fin depth to be determined
on site

door/window schedule

W1	1500x1500	Casement	6
W2	1500x900	"	4
D1	1500x2100	Steel	2

NOTES:

- 1- this drawing is protected under the copyright act and cannot be used or reproduced in part or in whole.
- 2- all dimensions are in mm unless stated.
- 3- the contractor to check and verify dimensions before commencing of works and that any discrepancy be reported to the architect.
- 4- all dimensions are to be read and not scaled.
- 5- construction.
- 6- pipe to be under all walls and 150mm above g.f.
- 7- window cills must be finished before internal plaster.



MINISTRY OF ROADS,
TRANSPORT,
PUBLIC WORKS &
INFRASTRUCTURE

PROPOSED
2NO
CLASSROOMS

NC-CDF
HOMA BAY COUNTY
CONSTITUENCY
2023
Dec 2021
1100



P
REPUBLIC OF KENYA



**NATIONAL GOVERNMENT CONSTITUENCY DEVELOPMENT FUND
HOMA BAY TOWN CONSTITUENCY**

**ENGINEERS' ESTIMATE
FOR**

**THE PROPOSED CONSTRUCTION OF A LIBRARY
AT**

**NYAKAHIA MIXED SECONDARY SCHOOL
IN**

HOMA BAY TOWN CONSTITUENCY

**PREPARED BY:
CLERK OF WORKS,
P.O BOX 240-40300,
HOMA BAY TOWN CONSTITUENCY**

**COUNTY WORKS OFFICE
HOMA BAY CONSTITUENCY
APPROVED BY: *[Signature]*
HOM/ BAY
SUB-COUNTY WORKS OFFICER
P.O BOX 89-40300
HOMABAY**



SUMMARY

ITEM	DESCRIPTION	AMOUNT (KSHS/CTS)
I	SUBSTRUCTURE CARRIED FROM PAGE 3	1,116,680.00
II	SUPERSTRUCTURE CARRIED FROM PAGE 4	204,350.00
III	WALLING CARRIED FROM PAGE 5	263,710.00
IV	WINDOWS CARRIED FROM PAGE 6	230,850.00
V	DOORS CARRIED FROM PAGE 7	38,800.00
VI	ROOFING CARRIED FROM PAGE 9	951,010.00
VII	FINISHES CARRIED FROM PAGE 10	999,600.00
TOTAL FOR MEASURED WORKS CARRIED TO GRAND SUMMARY		3,805,000.00

PROPOSED CONSTRUCTION OF LIBRARY AT NYAKAHIA MIXED SECONDARY SCHOOL

ITEM	DESCRIPTION	AMOUNT (KSHS/CTS)
<u>PRIME COST SUMS</u>		
A	Allow a provisional sum of Kenya Shillings Twenty Thousand for erection of a sign board and branding of Project in accordance with NG-CDF Board Specifications	20,000.00
B	Allow a provisional sum of Two Hundred and fifty Thousand for electrical works to the library	200,000.00
C	Allow a provisional sum of Thirty five Thousand shillings for construction of a ramp complete with balusters for access of people with disability	35,000.00
D	Allow for a provisional sum of One hundred thousand for supply and fixing of 18No. tables (tables to be fixed on the floor to ensure they are immovable)	100,000.00
E	Allow for a provisional sum of One hundred and fiftyfor thousand supply and fixing of 150 No. Chairs to the library	150,000.00
F	Allow for fixing of shelves and cabinets in the library area, Librarians office, borrowing area and the bookstore as directed by the Project Manager	250,000.00
TOTAL FOR PRIME COST SUMS CARRIED TO GRAND SUMMARY		755,000.00

PROPOSED CONSTRUCTION OF LIBRARY AT NYAKAHIA MIXED SECONDARY SCHOOL

GRAND SUMMARY		
ITEM	DESCRIPTION	AMOUNT (KSHS/CTS)
I	MEASURED WORKS	3,805,000.00
II	PRIME COST SUMS	755,000.00
	SUB-TOTAL I	4,560,000.00
III	ADD 3% FOR PROJECT MANAGEMENT COMMITTEE COST	144,000.00
III	ADD 2% FOR PROJECT MANAGEMENT	96,000.00
	GRAND SUMMARY FOR 2 NO. CLASSROOMS	4,800,000.00
	KSH.	

AMOUNT IN WORDS : FOUR MILLION MILLION EIGHT HUNDRED THOUSAND SHILLINGS ONLY

PREPARED BY :

NAME: OLIVER AKINYI

DESIGNATION : CLERK OF WORKS

SIGNATURE:

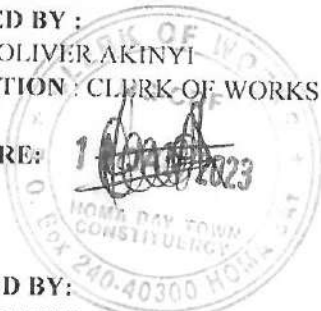

APPROVED BY:

NAME: WALTER KANDIAWO

DESIGNATION : SUB COUNTY WORKS OFFICER

SIGNATURE: COUNTY WORKS OFFICER



 WALTER KANDIAWO
 P. O. Box 89 40300,
 HOMA BAY

ALL RATES ARE INCLUSIVE OF 16% V.A.T

NOTES:

- 1- this drawing is protected under the copyright act and shall not be used or reproduced in part or in whole
- 2- all dimensions are in millimeters unless stated
- 3- the contractor to check and verify dimensions before commencing work and that any discrepancy to be reported to the architect immediately.
- 4- all dimensions are to be read and not scaled
- 5- pipes to be under slabs and 150mm above floor
- 6- manholes to be finished before normal plaster
- 7- all walls under slabs to be treated with anti-termite compound.
- 8- all the works to be detailed.
- 9- the depth to be determined on site.
- 10- all walls to be reinforced with reinforcement at every alternate course
- 11- mechanical
- 12- all plumbing and drainage works to comply with county regulations
- 13- all service stacks to be accessed from all floors
- 14- all testing of pipes to be complete before plastering
- 15- maximum slope on drain pipes shall be 2%
- 16- the storm water pipe to comply to BS 5256
- 17- all pipes passing under slabs and driveway to be encased with 150mm concrete surround

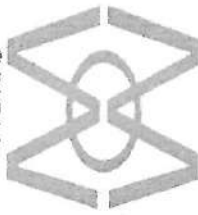
DIRECTORATE OF PUBLIC WORKS



PROPOSED LIBRARY BLOCK

client:

NYAKAHIA MIXED SEC SCHOOL

ground floor plan elevations & section

V.V.K

tel: 0773-524650

date: Dec 2023

scale: 1:100

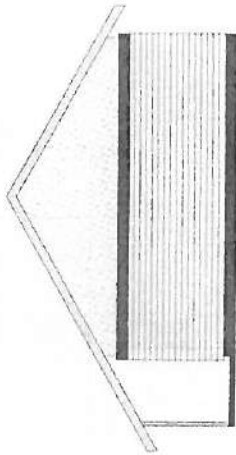

SIDE ELEVATION

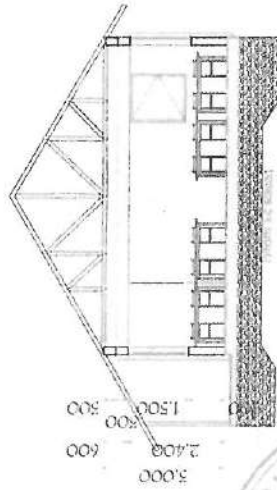

SECTION ELEVATION

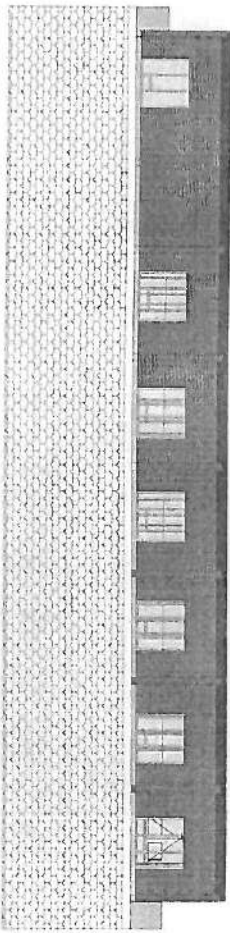

REAR ELEVATION

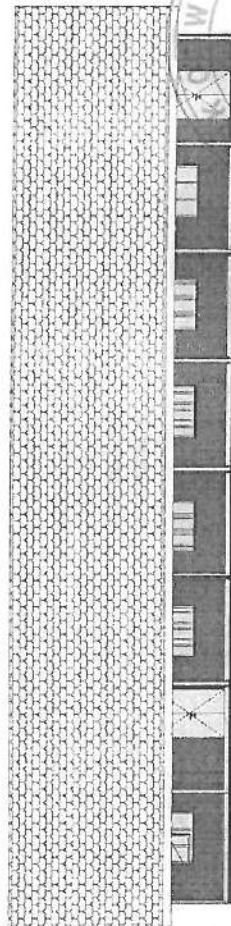

FRONT ELEVATION

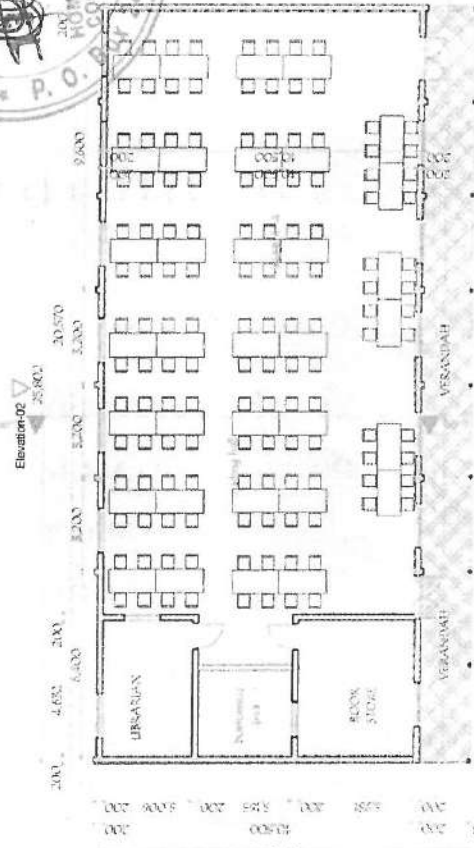

GROUND FLOOR PLAN

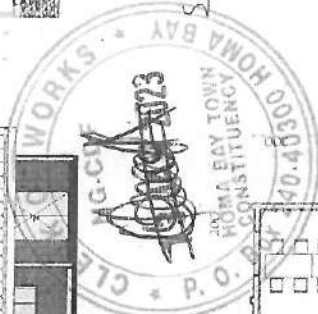

DATE: 20/12/2023

BY: V.V.K

FOR: NYAKAHIA MIXED SEC SCHOOL

NO	DESCRIPTION	DATE
01	ISSUED FOR TENDER	20/12/2023
02	ISSUED FOR TENDER	20/12/2023
03	ISSUED FOR TENDER	20/12/2023



REPUBLIC OF KENYA



**NATIONAL GOVERNMENT CONSTITUENCY DEVELOPMENT FUND
HOMA BAY TOWN CONSTITUENCY**

**ENGINEERS ESTIMATE
FOR**

**THE PROPOSED RENOVATION OF 5 NO. CLASSROOMS
AT**

**WIOBIERO PRIMARY SCHOOL
IN**

HOMA BAY TOWN CONSTITUENCY

PREPARED BY:

CLERK OF WORKS,

P.O BOX 240-40300,

HOMA BAY TOWN CONSTITUENCY



APPROVED BY:

SUB-COUNTY WORKS OFFICER

P.O BOX 89-40300

HOMABAY

SUB-COUNTY WORKS OFFICER

HOMA BAY COUNTY

P. O. Box 89-40300,

HOMA BAY

PROPOSED RENOVATION OF 5 NO. CLASSROOMS AT WIOBIERO PRIMARY SCHOOL

<u>SUMMARY</u>		
ITEM	DESCRIPTION	AMOUNT (KSHS/CTS)
I	DEMOLITIONS AND ALTERATIONS CARRIED FROM PG/3	17,940.00
II	WINDOWS CARRIED FROM PAGE PG/5	64,600.00
III	DOORS AND ROOFING CARRIED FROM PAGE PG/6	502,260.00
IV	FINISHES CARRIED FROM PAGE PG/9	725,200.00
	TOTAL FOR BUILDER'S WORK CARRIED TO GRAND SUMMARY	1,310,000.00

PROPOSED RENOVATION OF 5 NO. CLASSROOMS AT WIOBIERO PRIMARY SCHOOL

ITEM	DESCRIPTION	AMOUNT (KSHS/CTS)
A	<p style="text-align: center;"><u>PRIME COST SUMS</u></p> <p><u>Sign Board</u></p> <p>Allow a provisional sum of Kenya Shilling Twenty Thousand for crection of a sign board and branding of Project in accordance with NG-CDF Board Specifications</p>	20,000.00
	TOTAL FOR PRIME COST SUMS CARRIED TO GRAND SUMMARY	20,000.00

PROPOSED RENOVATION OF 5 NO. CLASSROOMS AT WIOBIERO PRIMARY SCHOOL

ITEM	DESCRIPTION	AMOUNT (KSHS/CTS)
	<u>GRAND SUMMARY</u>	
I	BUILDER'S WORK	1,310,000.00
II	PRIME COST SUM	20,000.00
	SUB-TOTAL I	1,330,000.00
III	ADD PROJECT MANAGEMENT COMMITTEE COST	42,000.00
IV	ADD PROJECT MANAGEMENT AND ADMINISTRATION FEES BY PROJECT MANAGER	28,000.00
	SUB-TOTAL II	1,400,000.00
	GRAND SUMMARY	1,400,000.00
	KSH.	

AMOUNT IN WORDS : ONE MILLION FOUR HUNDRED THOUSAND SHILLINGS ONLY

PREPARED BY :

NAME: OLIVER AKINYI

DESIGNATION : CLERK OF WORKS

SIGNATURE:



APPROVED BY:

NAME: WALTER KANDIAWO

DESIGNATION : SUB COUNTY WORKS OFFICER

SIGNATURE:

COUNTY WORKS OFFICER
HOMA BAY COUNTY
P. O. Box 89-40300,
HOMA BAY

ALL RATES ARE INCLUSIVE OF 16% V.A.T



TO:
THE PROGRAMMES AND FIELD SERVICES CO-ORDINATION DEPARTMENT
NATIONAL GOVERNMENT CONSTITUENCIES DEVELOPMENT FUND BOARD

RE: PROPOSED RENOVATION OF 5NO. CLASSROOMS IN WIOBIERO PRIMARY SCHOOL

The Homabay Town Constituency Committee convened a ward meeting for public participation as per the National Government Constituencies Development Fund Act 2015 section 27(1) to generate projects given priority in the constituency. Wiobiero Primary School is located in Homabay Arujo Ward and was identified as one of the schools to be given priority.

Site investigation was done by the technical team and it was noticed that 5 No. Classrooms needed renovation. The following elements were identified:

- **Reroofing:** 3No. classrooms have worn out roofing sheets that leak during heavy rain therefore there was need for replacement with blue pre painted GCI sheets, while others are to be retained.
- **Glazing:** Glazing of the windows with 4mm thick clear sheet glass to be done to all the windows.
- **Floor finish:** The verandahs need re construction and the floors were in bad conditions and there was need to scrap off the existing floor screed in some areas and be replaced with tilling done with non-slip ceramic floor tiles both internally and on the verandahs.
- **Painting:** The paints on the walls are worn out and therefore the walls need new painting which is to be done with three coats of silk emulsion paint.

The attached Bills of Quantities gives the breakdown of the costs with the grand total at Kshs 1,400,000.

Yours Faithfully,

Oliver Akinyi,
Clerk Of Works
Confirmed by ;

W COUNTY WORKS OFFICER
HOMA BAY COUNTY
P. O. Box 89-40300,
HOMA BAY

Walter Karidiwo
Sub County Works Officer



REPUBLIC OF KENYA



**NATIONAL GOVERNMENT CONSTITUENCY DEVELOPMENT FUND
HOMA BAY TOWN CONSTITUENCY**

ENGINEERS ESTIMATE

FOR

THE PROPOSED RENOVATION OF 8NO. CLASSROOMS

AT

NYAUU PRIMARY SCHOOL

IN

HOMA BAY TOWN CONSTITUENCY

PREPARED BY:

CLERK OF WORKS,

P.O BOX 240-40300,

HOMA BAY TOWN CONSTITUENCY



APPROVED BY:

SUB-COUNTY WORKS OFFICER

P.O BOX 89-40300

HOMABAY

**COUNTY WORKS OFFICER
HOMA BAY COUNTY
P. O. Box 89-40300
HOMA BAY**

PROPOSED RENOVATION OF 8 NO. CLASSROOMS AT NYAUU PRIMARY SCHOOL

<u>SUMMARY</u>		
ITEM	DESCRIPTION	AMOUNT (KSHS/CTS)
I	DEMOLITIONS AND ALTERATIONS CARRIED FROM PG/3	96,180.00
II	WINDOWS CARRIED FROM PAGE PG/5	111,400.00
III	DOORS AND ROOFING CARRIED FROM PAGE PG/6	324,700.00
IV	FINISHES CARRIED FROM PAGE PG/9	1,351,600.00
	TOTAL FOR BUILDER'S WORK CARRIED TO GRAND SUMMARY	1,883,880.00

PROPOSED RENOVATION OF 8 NO. CLASSROOMS AT NYAUU PRIMARY SCHOOL

ITEM	DESCRIPTION	AMOUNT (KSHS/CTS)
A	<p style="text-align: center;"><u>PRIME COST SUMS</u></p> <p><u>Sign Board</u></p> <p>Allow a provisional sum of Kenya Shilling Twenty Thousand for erection of a sign board and branding of Project in accordance with NG-CDF Board Specifications</p>	20,000.00
	TOTAL FOR PRIME COST SUMS CARRIED TO GRAND SUMMARY	20,000.00



NATIONAL GOVERNMENT CONSTITUENCIES DEVELOPMENT FUND
HOMABAY TOWN CONSTITUENCY
Kabunde Multipurpose Hall
P.O BOX 240 Homabay, 40300
Email: cdfhomabaytown@ngcdf.go.ke | Website: www.ngcdf.go.ke

TO:

**THE PROGRAMMES AND FIELD SERVICES CO-ORDINATION DEPARTMENT
NATIONAL GOVERNMENT CONSTITUENCIES DEVELOPMENT FUND BOARD**

RE: PROPOSED RENOVATION OF 8 NO. CLASSROOMS IN NYAUU PRIMARY SCHOOL

The Homabay Town Constituency Committee convened a ward meeting for public participation as per the National Government Constituencies Development Fund Act 2015 section 27(1) to generate projects given priority in the constituency. Nyauu Primary School is located in Homabay East Ward and was identified as one of the schools to be given priority.

Site investigation was done by the technical team and it was noticed that 8 No. Classrooms needed renovation. The following elements were identified:

- **Reroofing:** 2 No. classrooms have worn out roofing sheets that leak during heavy rain therefore there was need for replacement with blue pre painted GCI sheets, while others are to be retained.
- **Glazing:** Glazing of the windows with 4mm thick clear sheet glass to be done to all the windows.
- **Floor finish:** The floors were in bad conditions and there was need to scrap off the existing floor screed in some areas and be replaced with tilling done with non-slip ceramic floor tiles both internally and on the verandahs.
- **Painting:** The paints on the walls are worn out and therefore the walls need new painting which is to be done with three coats of silk emulsion paint.

The attached Bills of Quantities gives the breakdown of the costs with the grand total at Kshs 2,000,000.

Yours Faithfully,

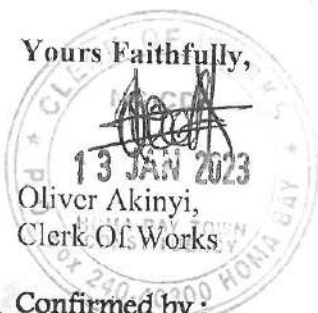

Oliver Akinyi,
Clerk Of Works

Confirmed by;

**COUNTY WORKS OFFICER
HOMA BAY COUNTY
P. O. Box 89-40300,
HOMA BAY**

Walter Kandiawo
Sub County Works Officer

PROPOSED RENOVATION OF 8 NO. CLASSROOMS AT NYAUU PRIMARY SCHOOL

ITEM	DESCRIPTION	AMOUNT (KSHS/CTS)
<u>GRAND SUMMARY</u>		
I	BUILDER'S WORK	1,883,880.00
II	PRIME COST SUM	20,000.00
SUB-TOTAL I		1,903,880.00
III	ADD PROJECT MANAGEMENT COMMITTEE COST	57,672.00
IV	ADD PROJECT MANAGEMENT AND ADMINISTRATION FEES BY PROJECT MANAGER	38,448.00
SUB-TOTAL II		2,000,000.00
GRAND SUMMARY		2,000,000.00
	KSH.	

AMOUNT IN WORDS : TWO MILLION SHILLINGS ONLY.

PREPARED BY :
 NAME: OLIVER AKINYI
 DESIGNATION : CLERK OF WORKS

SIGNATURE:

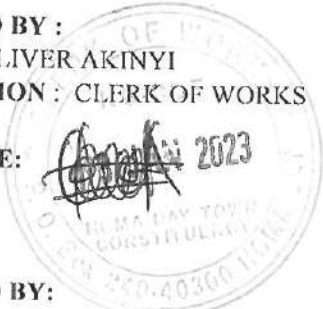

APPROVED BY:
 NAME: WALTER KANDIAWO
 DESIGNATION : SUB COUNTY WORKS OFFICER

[Handwritten Signature]
 COUNTY WORKS OFFICER
 HOMA BAY COUNTY
 P. O. Box 89-40300
 HOMA BAY

SIGNATURE:

[Handwritten Signature]

ALL RATES ARE INCLUSIVE OF 16% V.A.T



NATIONAL GOVERNMENT CONSTITUENCIES DEVELOPMENT FUND
HOMABAY TOWN CONSTITUENCY
Kabunde Multipurpose Hall
P.O BOX 240 Homabay, 40300
Email: cdfhomabaytown@ngcdf.go.ke | Website: www.ngcdf.go.ke

TO:

**THE PROGRAMMES AND FIELD SERVICES CO-ORDINATION DEPARTMENT
NATIONAL GOVERNMENT CONSTITUENCIES DEVELOPMENT FUND BOARD**

RE: PROPOSED RENOVATION OF 8 NO. CLASSROOMS IN NYAUU PRIMARY SCHOOL

The Homabay Town Constituency Committee convened a ward meeting for public participation as per the National Government Constituencies Development Fund Act 2015 section 27(1) to generate projects given priority in the constituency. Nyauu Primary School is located in Homabay East Ward and was identified as one of the schools to be given priority.

Site investigation was done by the technical team and it was noticed that 8 No. Classrooms needed renovation. The following elements were identified:

- **Reroofing:** 2 No. classrooms have worn out roofing sheets that leak during heavy rain therefore there was need for replacement with blue pre painted GCI sheets, while others are to be retained.
- **Glazing:** Glazing of the windows with 4mm thick clear sheet glass to be done to all the windows.
- **Floor finish:** The floors were in bad conditions and there was need to scrap off the existing floor screed in some areas and be replaced with tilling done with non- slip ceramic floor tiles both internally and on the verandahs.
- **Painting:** The paints on the walls are worn out and therefore the walls need new painting which is to be done with three coats of silk emulsion paint.

The attached Bills of Quantities gives the breakdown of the costs with the grand total at Kshs 2,000,000.

Yours Faithfully,



Oliver Akinyi,
Clerk Of Works

Confirmed by ;

**COUNTY WORKS OFFICER
HOMA BAY COUNTY
P. O. Box 89-40300,
HOMA BAY**

Walter Kandiawo
Sub County Works Officer



REPUBLIC OF KENYA



**NATIONAL GOVERNMENT CONSTITUENCY DEVELOPMENT FUND
HOMA BAY TOWN CONSTITUENCY**

**ENGINEERS ESTIMATE
FOR**

**THE PROPOSED CONSTRUCTION OF 2 CLASSROOMS
AT**

**SINANGI PRIMARY SCHOOL
IN**

HOMA BAY TOWN CONSTITUENCY

PREPARED BY:

CLERK OF WORKS,

P.O BOX 240-40300,

HOMA BAY TOWN CONSTITUENCY

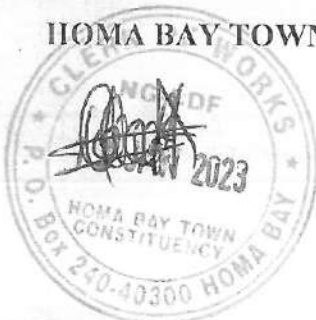

APPROVED BY:

SUB-COUNTY WORKS OFFICER

P.O BOX 89-40300

HOMABAY

SUB-COUNTY WORKS OFFICER
HOMA BAY COUNTY
P. O. Box 89-40300,
▼ HOMA BAY

PROPOSED CONSTRUCTION OF 2 NO. CLASSROOMS AT SINANGI PRIMARY SCHOOL

SUMMARY

ITEM	DESCRIPTION	AMOUNT (KSHS/CTS)
I	SUBSTRUCTURE CARRIED FROM PAGE 3	854,721.00
II	SUPERSTRUCTURE CARRIED FROM PAGE 4	72,810.00
III	WALLING CARRIED FROM PAGE 5	230,310.00
IV	WINDOWS CARRIED FROM PAGE 6	84,150.00
V	DOORS CARRIED FROM PAGE 7	47,150.00
VI	ROOFING CARRIED FROM PAGE 9	425,072.00
VII	FINISHES CARRIED FROM PAGE 10	405,020.00
	TOTAL FOR MEASURED WORKS CARRIED TO GRAND SUMMARY	2,119,233.00

PROPOSED CONSTRUCTION OF 2 NO. CLASSROOMS AT SINANGI PRIMARY SCHOOL

ITEM	DESCRIPTION	AMOUNT (KSHS/CTS)
<u>PRIME COST SUMS</u>		
A	Allow a provisional sum of Kenya Shillings Twenty Thousand for erection of a sign board and branding of Project in accordance with NG-CDF Board Specifications	20,000.00
TOTAL FOR PRIME COST SUMS CARRIED TO GRAND SUMMARY		20,000.00

PROPOSED CONSTRUCTION OF 2 NO. CLASSROOMS AT SINANGI PRIMARY SCHOOL

GRAND SUMMARY

ITEM	DESCRIPTION	AMOUNT (KSHS/CTS)
I	MEASURED WORKS	2,119,233.00
II	PRIME COST SUMS	20,000.00
	SUB-TOTAL 1	2,139,233.00
III	ADD 3% FOR PROJECT MANAGEMENT COMMITTEE COST	60,000.00
III	ADD 2% FOR PROJECT MANAGEMENT	40,000.00
	GRAND SUMMARY FOR 2 NO. CLASSROOMS	2,239,233.00
	KSH.	

AMOUNT IN WORDS : TWO MILLION TWO HUNDRED AND THIRTY NINE THOUSAND TWO HUNDRED AND THIRTY THREE SHILLINGS ONLY

PREPARED BY :

NAME: OLIVER AKINYI

DESIGNATION : CLERK OF WORKS

SIGNATURE:



APPROVED BY:

NAME: WALTER KANDIAWO

DESIGNATION : SUB COUNTY WORKS OFFICER

SIGNATURE:

 SUB COUNTY WORKS OFFICER
 HOMA BAY COUNTY
 P. O. Box 89-40300,
 HOMA BAY

ALL RATES ARE INCLUSIVE OF 16% V.A.T

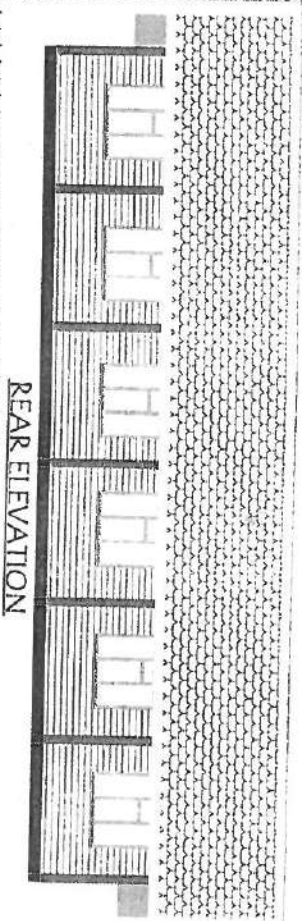

REAR ELEVATION



FRONT ELEVATION

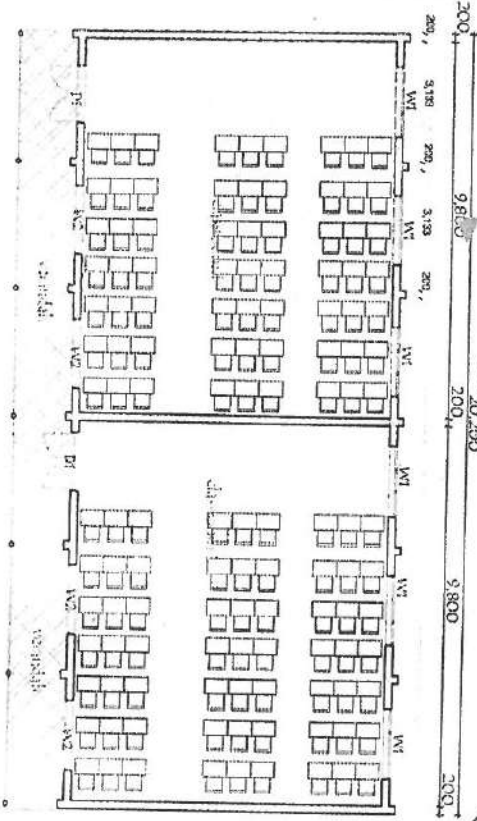

GROUND FLOOR PLAN

North Elevation
South Elevation

COUNTY CLERK OFFICE
HOMA BAY COUNTY
P. O. Box 89-40300,
HOMA BAY

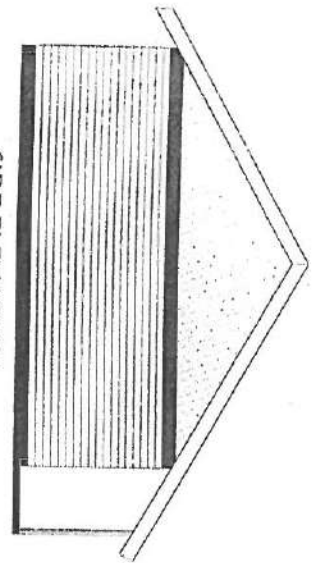

SIDE ELEVATION

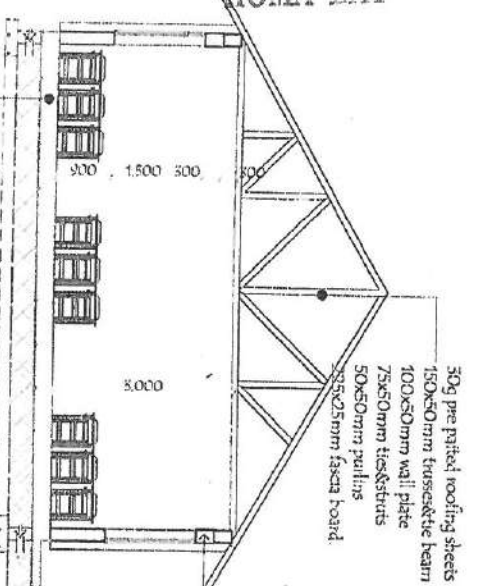

SECTION ELEVATION

19mm thick fl. slab
150mm conc. fl. slab
bric mesh class A142
500G dpm
approved insecticide
50mm minimum blinding
300mm hardcore filling
can refer to be determined
on site

door/window schedule

WT	1500X1500	Casement	6
WT	1500X900	"	4
DF	1500X1400	Steel	2

NOTES:

- 1- this drawing is protected under the copyright act and cannot be used or reproduced in part or in whole.
- 2- all dimensions are in mm unless stated.
- 3- the contractor to check and verify dimensions before commencing of works and that any discrepancy to be reported to the architect.
- 4- all dimensions are to be read and not scaled.
- 5- construction:
- 5-1- to be under all walls and 150mm above g.l.
- 6- window cills must be finished before internal plaster.



MINISTRY OF ROADS,
TRANSPORT,
PUBLIC WORKS &
INFRASTRUCTURE

PROPOSED
2 NO
CLASSROOMS



client:
HOMA BAY COUNTY
Dec 2014 403000
1400



REPUBLIC OF KENYA



NATIONAL GOVERNMENT CONSTITUENCY DEVELOPMENT FUND

HOMA BAY TOWN CONSTITUENCY

ENGINEERS ESTIMATE

FOR

THE PROPOSED CONSTRUCTION OF 4 NO. CLASSROOMS,

AT

ST. PETERS DISII MIXED SECONDARY SCHOOL

IN

HOMA BAY TOWN CONSTITUENCY

PREPARED BY:

CLERK OF WORKS,

P.O BOX 240-40300,

HOMA BAY TOWN CONSTITUENCY

COUNTY WORKS OFFICER
HOMA BAY COUNTY

APPROVED BY

SUB-COUNTY WORKS OFFICER

P.O BOX 89-40300

HOMABAY



CONSTRUCTION OF 4 NO. CLASSROOMS AT ST. PETERS DISII MIXED SECONDARY SCHOOL

SUMMARY

ITEM	DESCRIPTION	AMOUNT (KSHS/CTS)
I	SUBSTRUCTURE CARRIED FROM PAGE 3	1,691,740.00
II	SUPERSTRUCTURE CARRIED FROM PAGE 4	146,340.00
III	WALLING CARRIED FROM PAGE 5	557,570.00
IV	WINDOWS CARRIED FROM PAGE 6	168,300.00
V	DOORS CARRIED FROM PAGE 7	100,600.00
VI	ROOFING CARRIED FROM PAGE 9	849,760.00
VII	FINISHES CARRIED FROM PAGE 10	1,016,340.00
TOTAL FOR MEASURED WORKS CARRIED TO GRAND SUMMARY		4,530,650.00

CONSTRUCTION OF 4 NO. CLASSROOMS AT ST. PETERS DISII MIXED SECONDARY SCHOOL

DESCRIPTION	AMOUNT (KSHS/CTS)
<u>PRIME COST SUMS</u>	
A Allow a provisional sum of Kenya Shillings Twenty Thousand for erection of a sign board and branding of Project in accordance with NG-CDF Board Specifications	20,000.00
B Allow a provisional sum of Two Hundred Thousand for electrical works to the 4 No. Classrooms	200,000.00
C Allow a provisional sum of Forty Thousand shillings for construction of a ramp for access of people with disability	40,000.00
TOTAL FOR PRIME COST SUMS CARRIED TO GRAND SUMMARY	220,000.00

CONSTRUCTION OF 4 NO. CLASSROOMS AT ST. PETERS DISII MIXED SECONDARY SCHOOL

GRAND SUMMARY		
	DESCRIPTION	AMOUNT (KSHS/CTS)
I	MEASURED WORKS	4,530,650.00
II	PRIME COST SUMS	220,000.00
	SUB-TOTAL I	4,750,650.00
III	ADD 3% FOR PROJECT MANAGEMENT COMMITTEE COST	150,000.00
III	ADD 2% FOR PROJECT MANAGEMENT	99,350.00
	GRAND SUMMARY FOR 2 NO. CLASSROOMS	KSH. 5,000,000.00

AMOUNT IN WORDS : FIVE MILLION SHILLINGS ONLY

PREPARED BY :

NAME: OLIVER AKINYI

DESIGNATION : CLERK OF WORKS

SIGNATURE:

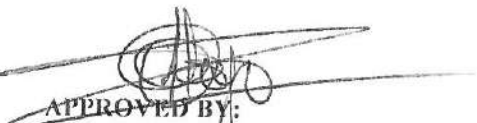

APPROVED BY:

NAME: WALTER KANDIAWO

DESIGNATION : SUB-COUNTY WORKS OFFICER

**COUNTY WORKS OFFICER
HOMA BAY COUNTY**

SIGNATURE:

P.O. Box 89-40 H.B.
W.K.
HOMA BAY

ALL RATES ARE INCLUSIVE OF 16% V.A.T

- 1. All materials to be used shall be of the highest quality and shall be approved by the Engineer.
- 2. All materials are to be new unless otherwise specified.
- 3. The contractor to check and verify dimensions before commencing work, and the Engineer to be notified if any discrepancy is found.
- 4. All dimensions are to be read and not scaled.
- 5. The contractor to be responsible for the construction.
- 6. The contractor to be responsible for the workmanship.
- 7. The contractor to be responsible for the safety of all workers.
- 8. The contractor to be responsible for the environment.
- 9. The contractor to be responsible for the health and safety of all workers.
- 10. The contractor to be responsible for the quality of workmanship.
- 11. The contractor to be responsible for the completion of the work.
- 12. The contractor to be responsible for the maintenance of the work.
- 13. The contractor to be responsible for the repair of the work.
- 14. The contractor to be responsible for the replacement of the work.
- 15. The contractor to be responsible for the removal of the work.
- 16. The contractor to be responsible for the disposal of the work.
- 17. The contractor to be responsible for the storage of the work.
- 18. The contractor to be responsible for the transportation of the work.
- 19. The contractor to be responsible for the unloading of the work.
- 20. The contractor to be responsible for the loading of the work.
- 21. The contractor to be responsible for the unloading of the work.
- 22. The contractor to be responsible for the loading of the work.
- 23. The contractor to be responsible for the unloading of the work.
- 24. The contractor to be responsible for the loading of the work.
- 25. The contractor to be responsible for the unloading of the work.
- 26. The contractor to be responsible for the loading of the work.
- 27. The contractor to be responsible for the unloading of the work.
- 28. The contractor to be responsible for the loading of the work.
- 29. The contractor to be responsible for the unloading of the work.
- 30. The contractor to be responsible for the loading of the work.

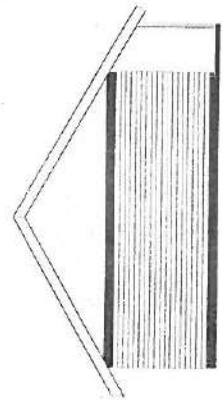

SIDE ELEVATION

- 1. All materials to be used shall be of the highest quality and shall be approved by the Engineer.
- 2. All materials are to be new unless otherwise specified.
- 3. The contractor to check and verify dimensions before commencing work, and the Engineer to be notified if any discrepancy is found.
- 4. All dimensions are to be read and not scaled.
- 5. The contractor to be responsible for the construction.
- 6. The contractor to be responsible for the workmanship.
- 7. The contractor to be responsible for the safety of all workers.
- 8. The contractor to be responsible for the environment.
- 9. The contractor to be responsible for the health and safety of all workers.
- 10. The contractor to be responsible for the quality of workmanship.
- 11. The contractor to be responsible for the completion of the work.
- 12. The contractor to be responsible for the maintenance of the work.
- 13. The contractor to be responsible for the repair of the work.
- 14. The contractor to be responsible for the replacement of the work.
- 15. The contractor to be responsible for the removal of the work.
- 16. The contractor to be responsible for the disposal of the work.
- 17. The contractor to be responsible for the storage of the work.
- 18. The contractor to be responsible for the transportation of the work.
- 19. The contractor to be responsible for the unloading of the work.
- 20. The contractor to be responsible for the loading of the work.
- 21. The contractor to be responsible for the unloading of the work.
- 22. The contractor to be responsible for the loading of the work.
- 23. The contractor to be responsible for the unloading of the work.
- 24. The contractor to be responsible for the loading of the work.
- 25. The contractor to be responsible for the unloading of the work.
- 26. The contractor to be responsible for the loading of the work.
- 27. The contractor to be responsible for the unloading of the work.
- 28. The contractor to be responsible for the loading of the work.
- 29. The contractor to be responsible for the unloading of the work.
- 30. The contractor to be responsible for the loading of the work.

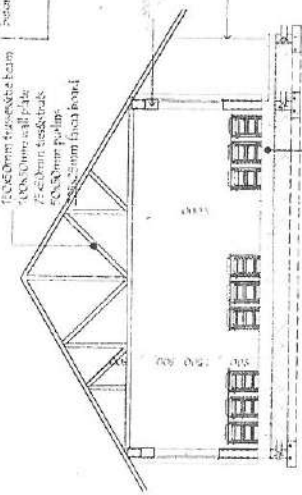

SECTION ELEVATION

- 1. All materials to be used shall be of the highest quality and shall be approved by the Engineer.
- 2. All materials are to be new unless otherwise specified.
- 3. The contractor to check and verify dimensions before commencing work, and the Engineer to be notified if any discrepancy is found.
- 4. All dimensions are to be read and not scaled.
- 5. The contractor to be responsible for the construction.
- 6. The contractor to be responsible for the workmanship.
- 7. The contractor to be responsible for the safety of all workers.
- 8. The contractor to be responsible for the environment.
- 9. The contractor to be responsible for the health and safety of all workers.
- 10. The contractor to be responsible for the quality of workmanship.
- 11. The contractor to be responsible for the completion of the work.
- 12. The contractor to be responsible for the maintenance of the work.
- 13. The contractor to be responsible for the repair of the work.
- 14. The contractor to be responsible for the replacement of the work.
- 15. The contractor to be responsible for the removal of the work.
- 16. The contractor to be responsible for the disposal of the work.
- 17. The contractor to be responsible for the storage of the work.
- 18. The contractor to be responsible for the transportation of the work.
- 19. The contractor to be responsible for the unloading of the work.
- 20. The contractor to be responsible for the loading of the work.
- 21. The contractor to be responsible for the unloading of the work.
- 22. The contractor to be responsible for the loading of the work.
- 23. The contractor to be responsible for the unloading of the work.
- 24. The contractor to be responsible for the loading of the work.
- 25. The contractor to be responsible for the unloading of the work.
- 26. The contractor to be responsible for the loading of the work.
- 27. The contractor to be responsible for the unloading of the work.
- 28. The contractor to be responsible for the loading of the work.
- 29. The contractor to be responsible for the unloading of the work.
- 30. The contractor to be responsible for the loading of the work.

Door & Window schedule	
UNIT	DESCRIPTION
D1	1500X2400 steel
W1	1500X1500 Casement
W2	1500X900
D2	1500X2400 steel

MINISTRY OF ROADS,
TRANSPORT,
PUBLIC WORKS &
INFRASTRUCTURE

PROPOSED 4 NO
CLASSROOMS

ST. PETER'S DISH
MIXED
SECONDARY
SCHOOL

DATE: 11/00
SCALE: 1:100

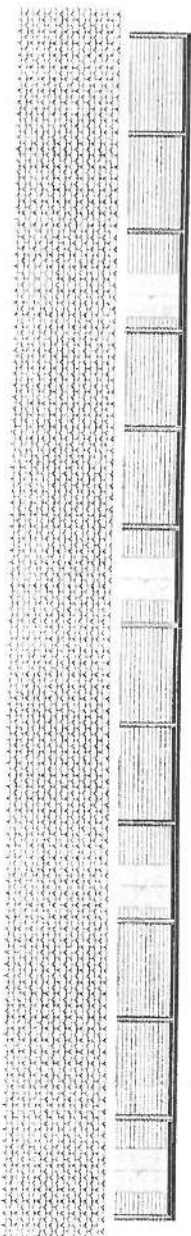

SOUTH ELEVATION

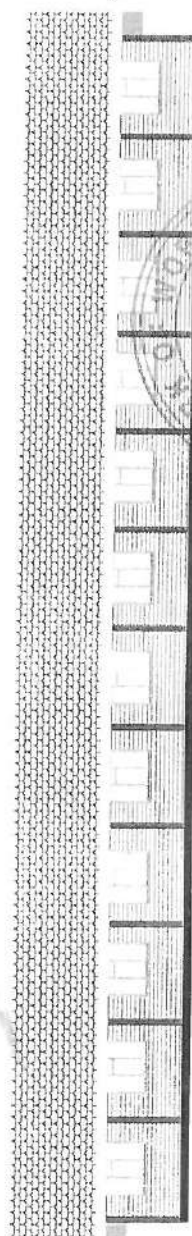

NORTH ELEVATION
COUNTY WORKS OFFICER
TOMA BAY COUNTY

W.K. RAY
240-403388

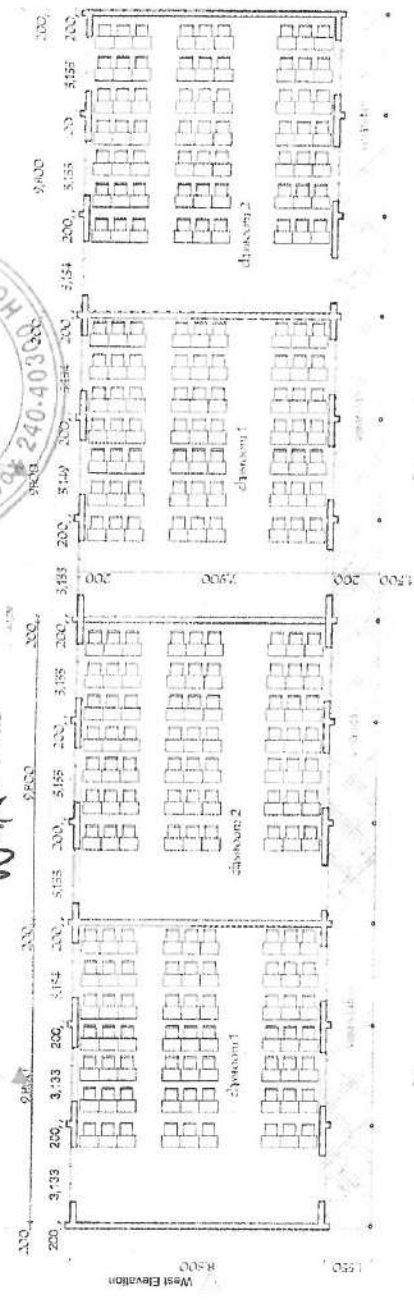

GROUND FLOOR SLAB



REPUBLIC OF KENYA



NATIONAL GOVERNMENT CONSTITUENCY DEVELOPMENT FUND
HOMA BAY TOWN CONSTITUENCY

ENGINEERS ESTIMATE
FOR

THE PROPOSED RENOVATION OF 3 CLASSROOMS
AT

NYAKUNE PRIMARY SCHOOL
IN

HOMA BAY TOWN CONSTITUENCY

PREPARED BY:

CLERK OF WORKS,

P.O BOX 240-40300,

HOMA BAY TOWN CONSTITUENCY



APPROVED BY:

SUB-COUNTY WORKS OFFICER

P.O BOX 89-40300

HOMABA COUNTY WORKS OFFICER

HOMA BAY COUNTY

P. O. Box 89-40300,

HOMA BAY

PROPOSED RENOVATION OF 3NO. CLASSROOMS AT NYAKUNE PRIMARY SCHOOL

<u>SUMMARY</u>		
ITEM	DESCRIPTION	AMOUNT (KSHS/CTS)
II	WINDOWS CARRIED FROM PAGE 1	52,900.00
III	TOTAL FOR DOORS AND VERANDAH CARRIED FROM PAGE 2	69,750.00
IV	FINISHES CARRIED FROM PAGE 3	589,500.00
	TOTAL FOR BUILDER'S WORK CARRIED TO GRAND SUMMARY	712,150.00

ITEM	DESCRIPTION	AMOUNT (KSHS/CTS)
<u>PRIME COST SUMS</u>		
	<u>Sign Board</u>	
A	Allow a provisional sum of Kenya Shilling Twenty Thousand for erection of a sign board and branding of Project in accordance with NG-CDF Board Specifications	20,000.00
B	Allow a provisional sum of Kenya Shillings Thirty thousand for construction of ramp for access of people with disability	30,000.00
TOTAL FOR PRIME COST SUMS CARRIED TO GRAND SUMMARY		50,000.00

PROPOSED RENOVATION OF 3NO. CLASSROOMS AT NYAKUNE PRIMARY SCHOOL

ITEM	DESCRIPTION	AMOUNT (KSHS/CTS)
<u>GRAND SUMMARY</u>		
I	BUILDER'S WORK	712,150.00
II	PRIME COST SUM	50,000.00
	SUB-TOTAL I	762,150.00
III	ADD PROJECT MANAGEMENT COMMITTEE COST	22,850.00
IV	ADD PROJECT MANAGEMENT AND ADMINISTRATION FEES BY PROJECT MANAGER	15,000.00
	SUB-TOTAL II	
	GRAND SUMMARY	800,000.00
	KSH.	

AMOUNT IN WORDS : EIGHT HUNDRED THOUSAND SHILLINGS ONLY.

PREPARED BY :
 NAME: OLIVER AKINYI
 DESIGNATION : CLERK OF WORKS

SIGNATURE: 

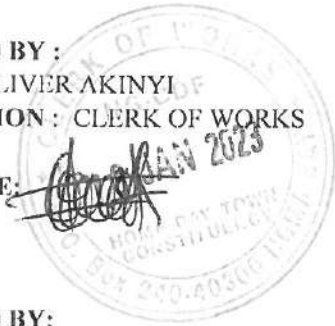

APPROVED BY:
 NAME: WALTER KANDIAWO
 DESIGNATION : SUB COUNTY WORKS OFFICER

 COUNTY WORKS OFFICER
 HOMA BAY COUNTY
 P. O. Box 89-40300,
 HOMA BAY

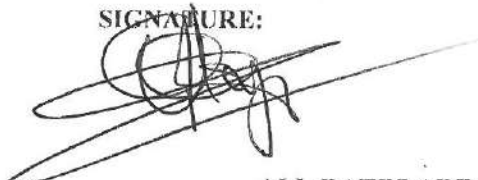
SIGNATURE: 

ALL RATES ARE INCLUSIVE OF 16% V.A.T



TO:

**THE PROGRAMMES AND FIELD SERVICES CO-ORDINATION DEPARTMENT
NATIONAL GOVERNMENT CONSTITUENCIES DEVELOPMENT FUND BOARD**

RE: PROPOSED RENOVATION OF 3NO. CLASSROOMS IN NYAKUNE PRIMARY SCHOOL

The Homabay Town Constituency Committee convened a ward meeting for public participation as per the National Government Constituencies Development Fund Act 2015 section 27(1) to generate projects given priority in the constituency. Nyakune Primary School is located in Homabay West Ward and was identified as one of the schools to be given priority.

Site investigation was done by the technical team and it was noticed that 3No. Classrooms needed renovation. The following elements were identified:

- **Glazing:** Glazing of the windows with 4mm thick clear sheet glass to be done to all the windows.
- **Floor finish:** The floors were in bad conditions and there was need to scrap off the existing floor screed and be replaced with tilling done with non-slip ceramic floor tiles both internally and on the verandahs.
- **Plastering and Painting:** The walls had major and minor cracks which need to be plastered with cement and sand finished smooth in the internal and rendered on the external complete with painting with three coats of silk emulsion paint.

The attached Bills of Quantities gives the breakdown of the costs with the grand total at Kshs 800,000

Yours Faithfully,



Oliver Akinyi,
Clerk Of Works

Confirmed by:

**COUNTY WORKS OFFICER
HOMA BAY COUNTY
P. O. Box 89-40300,
HOMA BAY**

Walter Kandiawo
Sub County Works Officer



REPUBLIC OF KENYA



NATIONAL GOVERNMENT CONSTITUENCY DEVELOPMENT FUND
HOMA BAY TOWN CONSTITUENCY

ENGINEERS ESTIMATE
FOR

THE PROPOSED CONSTRUCTION AND EQUIPPING OF 2 NO.
CLASSROOMS, CONSTRUCTION OF 4 DOOR PIT
LATRINE, FENCING OF 3 ACRES OF SCHOOL COMPOUND

AT

ACHIERO PRIMARY SCHOOL

IN

HOMA BAY TOWN CONSTITUENCY

PREPARED BY:

CLERK OF WORKS,

P.O BOX 240-40300,

HOMA BAY TOWN CONSTITUENCY

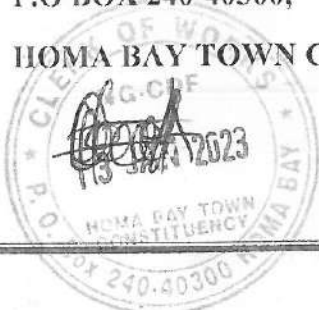

APPROVED BY:

SUB-COUNTY WORKS OFFICER

P.O BOX 89-40300

HOMABAY

COUNTY WORKS OFFICE
HOMA BAY COUNTY
P. O. Box 89-40300,
HOMA BAY

**CONSTRUCTION AND EQUIPPING OF 2 NO. CLASSROOMS, CONSTRUCTION OF 4 DOOR PIT LATRINE
FENCING OF THE SCHOOL COMPOUND AT ACHIERO PRIMARY SCHOOL**

NO.	DESCRIPTION	AMOUNT (KSHS/CTS)
<u>SUMMARY</u>		
I	SUBSTRUCTURE FROM PAGE PL/3	434,230.00
II	WALLING FROM PAGE PL/4	140,523.00
III	ROOFING FROM PAGE PL/5	46,830.00
IV	DOORS FROM PAGE PL/6	69,200.00
V	FINISHES FROM PAGE PL/7	36,750.00
VI	PAINTING AND DECORATION FROM PAGE PL/8	32,550.00
TOTAL FOR 4 NO. DOOR PIT LATRINE CARRIED TO GRAND SUMMARY		760,083.00

**CONSTRUCTION AND EQUIPPING OF 2 NO. CLASSROOMS, CONSTRUCTION OF 4 DOOR PIT LATRINE,
FENCING OF THE SCHOOL COMPOUND AT ACHIERO PRIMARY SCHOOL**

GRAND SUMMARY		
ITEM	DESCRIPTION	AMOUNT (KSHS/CTS)
I	MEASURED WORKS	2,084,810.00
II	PRIME COST SUMS	205,000.00
	GRAND SUMMARY FOR CONSTRUCTION AND EQUIPPING OF 2 NO. CLASSROOMS	2,289,810.00
	KSH.	

**AD CONSTRUCTION AND EQUIPPING OF 2 NO. CLASSROOMS, CONSTRUCTION OF 4 DOOR PIT LATRIN
FENCING OF THE SCHOOL COMPOUND AT ACHIERO PRIMARY SCHOOL**

GRAND SUMMARY				
ITEM	DESCRIPTION			AMOUNT (KSHS/CTS)
I	TOTAL FOR CONSTRUCTION AND EQUIPPING OF 2 NO. CLASSROOMS			2,289,810.00
II	TOTAL FOR CONSTRUCTION OF 4 DOOR PIT LATRINE			790,083.00
III	TOTAL FOR FENCING AND GATE INSTALLATION CARRIED TO GRAND SUMMARY			1,480,900.00
SUB TOTAL I				
TOTAL MEASURED WORKS AND PRIME COST SUMS				4,560,793.00
IV	ADD 3% FOR PROJECT MANAGEMENT COMMITTEE COST			144,000.00
V	ADD 2% FOR PROJECT MANAGEMENT			95,207.00
GRAND SUMMARY				4,800,000.00

AMOUNT IN WORDS : FOUR MILLION EIGHT HUNDRED THOUSAND SHILLINGS ONLY

PREPARED BY:

NAME: OLIVER AKINYI

DESIGNATION : CLERK OF WORKS

SIGNATURE:

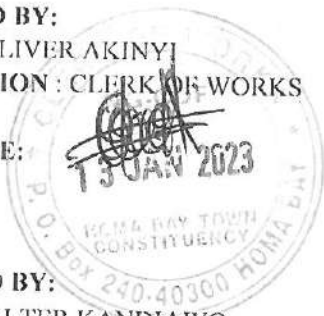

APPROVED BY:

NAME: WALTER KANDIAWO

DESIGNATION : SUB COUNTY WORKS OFFICER

SIGNATURE:

**COUNTY WORKS OFFICER
HOMA BAY COUNTY
P. O. Box 89-40300,
HOMA BAY**

ALL RATES ARE INCLUSIVE OF 16% V.A.T



REAR ELEVATION

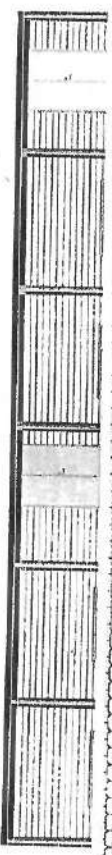

FRONT ELEVATION

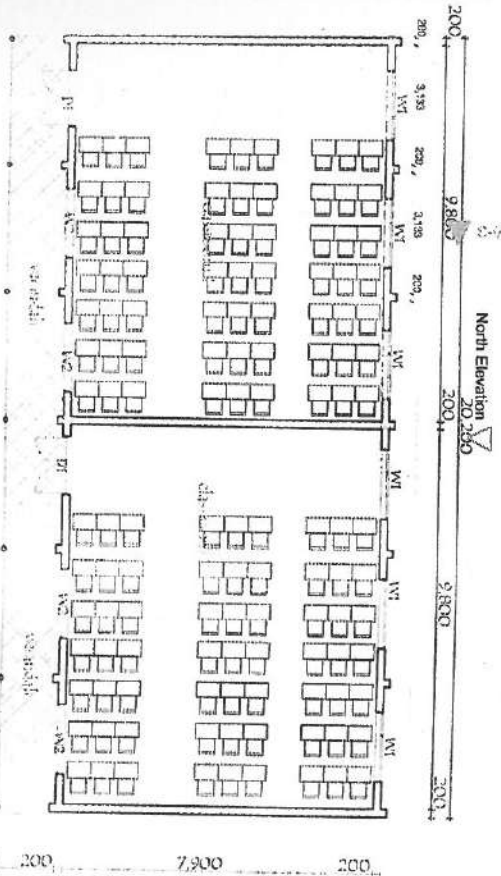

GROUND FLOOR PLAN

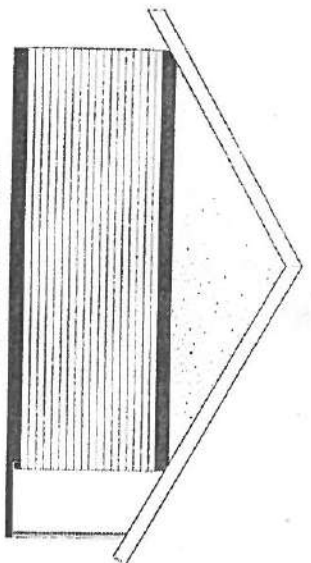

SIDE ELEVATION

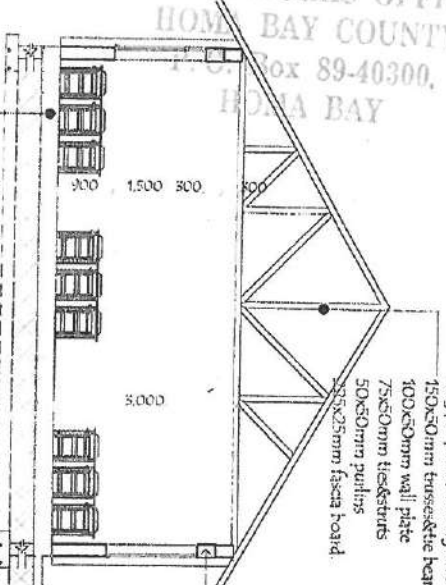

SECTION ELEVATION

door/window schedule

W1	1500X500	Casement	6
W2	1500X900	"	4
D1	1500X2400	Steel	2

COUNTY WORKS OFFICER
 HON. BAY COUNTY
 P.O. Box 89-40300,
 HONOLULU

NOTES:

- 1- this drawing is protected under the copyright act and cannot be used or reproduced in part or in whole.
- 2- all dimensions are in mm unless stated.
- 3- the contractor to check and verify dimensions before commencing of works and that any discrepancy to be reported to the architect.
- 4- all dimensions are to be read and not scaled.
- 5- construction:
- 5- spec to be under all walls and 150mm above gl.
- 6- window sills must be finished before internal plaster.



MINISTRY OF ROADS,
 TRANSPORT,
 PUBLIC WORKS &
 INFRASTRUCTURE

PROPOSED

2NO

CLASSROOMS



date: Dec 2021 1:00

100mm dia
pvc vent pipe.

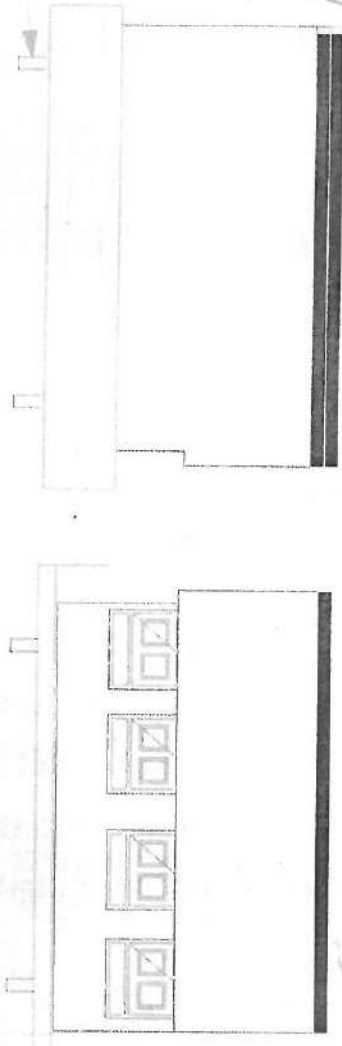

FRONT ELEVATION

REAR ELEVATION

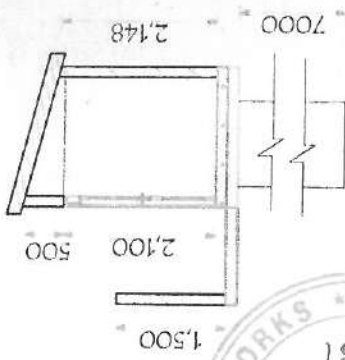

SIDE ELEVATION

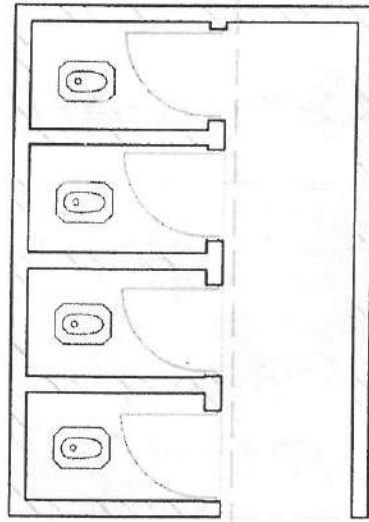

FLOOR PLAN

project:	PROPOSED 4DOOR PIT LATRINE
client:	NGCDF HOMA BAY TOWN P O BOX 249-40300 HOMA BAY.
DWN	W. Kandawo
SCALE	1:100
DATE	JANUARY 2022
 MINISTRY OF ROADS, TRANSPORT, PUBLIC WORKS & INFRASTRUCTURE	

[Signature]
 COUNTY ENGINEER
 HOMA BAY COUNTY
 P.O. BOX 59-40800,
 HOMA BAY

150 1,204 1,650 150



REPUBLIC OF KENYA



NATIONAL GOVERNMENT CONSTITUENCY DEVELOPMENT FUND
HOMA BAY TOWN CONSTITUENCY

ENGINEERS ESTIMATE
FOR

THE PROPOSED CONSTRUCTION OF 4 DOOR PIT LATRINE
AT

SINANGI PRIMARY SCHOOL
IN

HOMA BAY TOWN CONSTITUENCY

PREPARED BY:
CLERK OF WORKS,
P.O BOX 240-40300,
HOMA BAY TOWN CONSTITUENCY



COUNTY WORKS OFFICER
HOMA BAY COUNTY
APPROVED: Box 89-40300,
HOMA BAY
SUB-COUNTY WORKS OFFICER
P.O BOX 89-40300
HOMABAY

PROPOSED CONSTRUCTION OF 4 NO. DOOR PIT LATRINE AT SINANGI PRIMARY SCHOOL

ITEM	DESCRIPTION	AMOUNT (KSHS/CTS)
<u>SUMMARY</u>		
I	SUBSTRUCTURE FROM PAGE PL/3	434,230.00
II	WALLING FROM PAGE PL/4	140,523.00
III	ROOFING FROM PAGE PL/5	46,830.00
IV	DOORS FROM PAGE PL/6	69,200.00
V	FINISHES FROM PAGE PL/7	36,750.00
VI	PAINTING AND DECORATION FROM PAGE PL/8	32,550.00
TOTAL FOR 5 NO. DOOR PIT LATRINE CARRIED TO GRAND SUMMARY		760,083.00

PROPOSED CONSTRUCTION OF 4 NO. DOOR PIT LATRINE AT SINANGI PRIMARY SCHOOL

ITEM	DESCRIPTION	AMOUNT (KSHS/CTS)
	<u>PRIME COST SUMS</u>	
A	Allow a Prime Cost Sum of Kenya Shillings Thirty Thousand for construction of a ramp for access of people with disability	30,000.00
	<u>PROVISIONAL SUMS</u>	
	<u>Sign Board</u>	
B	Allow a provisional sum of Kenya Shilling Eighteen Thousand for erection of a sign board and branding of Project in accordance with NG-CDI' Board Specifications	20,000.00
	TOTAL FOR PRIME COST SUMS CARRIED TO GRAND SUMMARY	50,000.00

PROPOSED CONSTRUCTION OF 4 NO. DOOR PIT LATRINE AT SINANGI PRIMARY SCHOOL

ITEM	DESCRIPTION	AMOUNT (KSHS/CTS)
I	MEASURED WORKS	760,083.00
II	PRIME COST SUMS	50,000.00
	SUB-TOTAL I	760,083.00
II	ADD PROJECT MANAGEMENT COMMITTEE FEES	24,000.00
III	ADD PROJECT ADMINISTRATION FEES	15,917.00
	GRAND SUMMARY	800,000.00

AMOUNT IN WORDS : EIGHT HUNDRED THOUSAND SHILLINGS ONLY

PREPARED BY :

NAME: OLIVER AKINYI

DESIGNATION : 13 JAN 2023

SIGNATURE:

APPROVED BY:

NAME: WALTER KANDIAWO

DESIGNATION :

SIGNATURE:

ALL RATES ARE INCLUSIVE OF 16% V.A.T

100mm dia
pvc vent pipe.

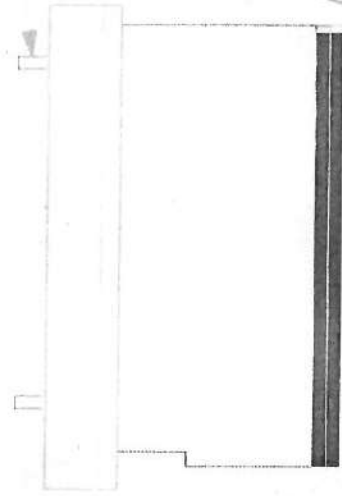

REAR ELEVATION

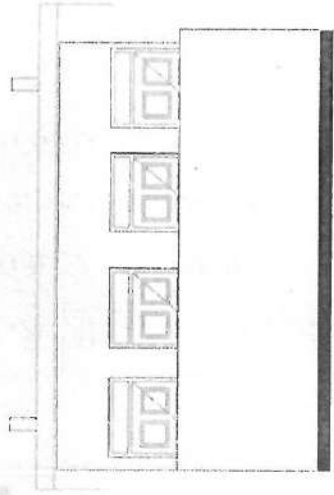

FRONT ELEVATION

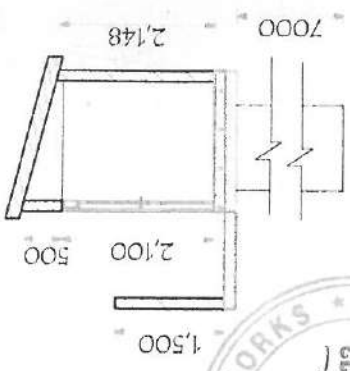

SIDE ELEVATION

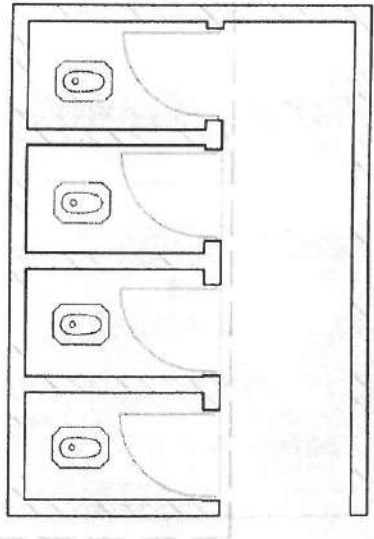

FLOOR PLAN

project:	PROPOSED 4DOOR PIT LATRINE
client:	NGCDF HOMA BAY TOWN P O BOX 249-40300 HOMA BAY.
PWN	W.Kandiawo
SCALE	1:100
DATE	JANUARY 2022
 MINISTRY OF ROADS, TRANSPORT, PUBLIC WORKS & INFRASTRUCTURE	

[Signature]
 COUNTY WORKS OFFICER
 HOMA BAY COUNTY
 P.O. BOX 249-40300,
 HOMA BAY



REPUBLIC OF KENYA



**NATIONAL GOVERNMENT CONSTITUENCY DEVELOPMENT FUND
HOMA BAY TOWN CONSTITUENCY**

**ENGINEERS ESTIMATE
FOR**

**THE PROPOSED LANDSCAPING
AT**

**OTARO PRIMARY SCHOOL
IN**

HOMA BAY TOWN CONSTITUENCY

PREPARED BY:

CLERK OF WORKS,

P.O BOX 240-40300,

HOMA BAY TOWN CONSTITUENCY

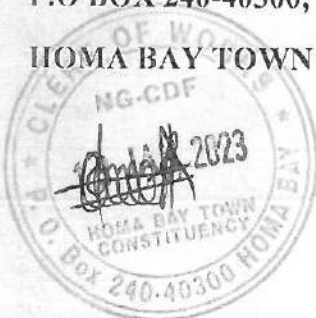

APPROVED BY:

SUB-COUNTY WORKS OFFICER

P.O BOX 89-40300

HOMABAY

**COUNTY WORKS OFFICER
HOMA BAY COUNTY
P. O. Box 89-40300,
HOMA BAY**

PROPOSED LANDSCAPPING OF OTARO PRIMARY SCHOOL

	DESCRIPTION	QTY	UNIT	RATE	AMOUNT (KSHS/CTS)
	ELEMENT NO 3 WALKWAYS				
A	Excavate grounds average 300mm deep and cart away arising debris from site as directed by project manager	195	SM	350	68,250.00
B	Fill with 300mm thick well compacted hardcore , well levelled and compacted in 150mm layers	90	CM	500	45,000.00
C	50mm filling as blinding to hard core , levelled and compacted.	195	SM	370	72,150.00
	TOTAL FOR WALKWAYS				185,400.00
	COLLECTION FOR LANDSCAPPING				
	TOTAL FOR DRIVEWAY AND DRAINAGE				417,315.00
	TOTAL FOR VEGETATION CARRIED TO SUMMARY				231,570.00
	TOTAL FOR WALKWAYS				185,400.00
	TOTAL FOR LANDSCAPPING				834,285.00

PROPOSED LANDSCAPPING OF OTARO PRIMARY SCHOOL

DESCRIPTION	AMOUNT (KSHS/CTS)
<u>PRIME COST SUMS</u>	
<u>PROVISIONAL SUMS</u>	
<u>Sign Board</u>	
B Allow a provisional sum of Kenya Shilling Twenty Thousand for erection of a sign board and branding of Project in accordance with NG-CIDF Board Specifications	20,000.00
TOTAL FOR PRIME COST SUMS CARRIED TO GRAND SUMMARY	20,000.00

PROPOSED LANDSCAPPING OF OTARO PRIMARY SCHOOL

	DESCRIPTION	AMOUNT (KSHS/CTS)
II	LANDSCAPPING	834,285.00
III	PRIME COST SUM	20,000.00
	SUB-TOTAL I	854,285.00
III	ADD PROJECT MANAGEMENT COMMITTEE COST	27,429.00
IV	ADD PROJECT MANAGEMENT AND ADMINISTRATION FEES BY PROJECT	18,286.00
	GRAND SUMMARY FOR FENCING , GATE INSTALLATION AND LANDSCAPPING	900,000.00

AMOUNT IN WORDS : NINE HUNDRED THOUSAND SHILLINGS ONLY

PREPARED BY :

NAME: OLIVER AKINYI
DESIGNATION: CLERK OF WORKS

SIGNATURE:  2023

APPROVED BY:

NAME: WALTER KANDIAWO
DESIGNATION : SUB COUNTY WORKS OFFICER

SIGNATURE: 

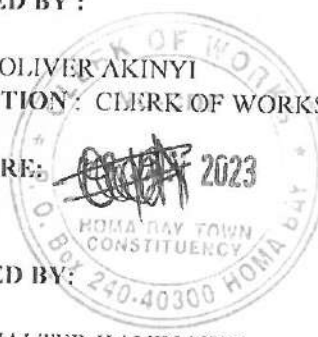
COUNTY WORKS OFFICER
HOMA BAY COUNTY
P. O. Box 89-40300,
HOMA BAY

ALL RATES ARE INCLUSIVE OF 16% V.A.T



REPUBLIC OF KENYA



NATIONAL GOVERNMENT CONSTITUENCY DEVELOPMENT FUND
HOMA BAY TOWN CONSTITUENCY

ENGINEERS ESTIMATE
FOR

THE PROPOSED CONSTRUCTION OF 2 NO. CLASSROOMS,
AT

ROBA PRIMARY SCHOOL
IN

HOMA BAY TOWN CONSTITUENCY

PREPARED BY:
CLERK OF WORKS,
P.O BOX 240-40300,
HOMA BAY TOWN CONSTITUENCY



APPROVED BY:
SUB-COUNTY WORKS OFFICER
P.O BOX 89-40300
HOMABAY COUNTY WORKS OFFICER
HOMA BAY COUNTY
P. O. Box 89-40300,
HOMA BAY

PROPOSED CONSTRUCTION OF 2 NO. CLASSROOMS AT ROBA PRIMARY SCHOOL

SUMMARY

ITEM	DESCRIPTION	AMOUNT (KSHS/CTS)
I	SUBSTRUCTURE CARRIED FROM PAGE 3	609,060.00
II	SUPERSTRUCTURE CARRIED FROM PAGE 4	72,810.00
III	WALLING CARRIED FROM PAGE 5	230,310.00
IV	WINDOWS CARRIED FROM PAGE 6	84,150.00
V	DOORS CARRIED FROM PAGE 7	47,150.00
VI	ROOFING CARRIED FROM PAGE 9	436,560.00
VII	FINISHES CARRIED FROM PAGE 10	399,960.00
	TOTAL FOR MEASURED WORKS CARRIED TO GRAND SUMMARY	1,880,000.00

PROPOSED CONSTRUCTION OF 2 NO. CLASSROOMS AT ROBA PRIMARY SCHOOL

M	DESCRIPTION	AMOUNT (KSHS/CTS)
A	<p style="text-align: center;"><u>PRIME COST SUMS</u></p> <p>Allow a provisional sum of Kenya Shillings Twenty Thousand for erection of a sign board and branding of Project in accordance with NG-CDF Board Specifications</p>	20,000.00
	TOTAL FOR PRIME COST SUMS CARRIED TO GRAND SUMMARY	20,000.00

GRAND SUMMARY		
ITEM	DESCRIPTION	AMOUNT (KSHS/CTS)
I	MEASURED WORKS	1,880,000.00
II	PRIME COST SUMS	20,000.00
	SUB-TOTAL 1	1,900,000.00
III	ADD 3% FOR PROJECT MANAGEMENT COMMITTEE COST	60,000.00
III	ADD 2% FOR PROJECT MANAGEMENT	40,000.00
	GRAND SUMMARY FOR 2 NO. CLASSROOMS	2,000,000.00
	KSH.	

AMOUNT IN WORDS : TWO MILLION SHILLINGS ONLY

PREPARED BY :

NAME: OLIVER AKINYI
 DESIGNATION : CLERK OF WORKS

SIGNATURE:

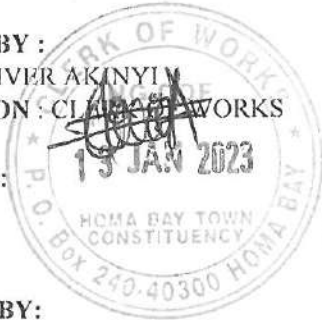

APPROVED BY:

NAME: WALTER KANDIAWO
 DESIGNATION : SUB COUNTY WORKS OFFICER

W
 COUNTY WORKS OFFICER
 HOMA BAY COUNTY
 P. O. Box 89-00200,
 HOMA BAY

SIGNATURE:

ALL RATES ARE INCLUSIVE OF 16% V.A.T

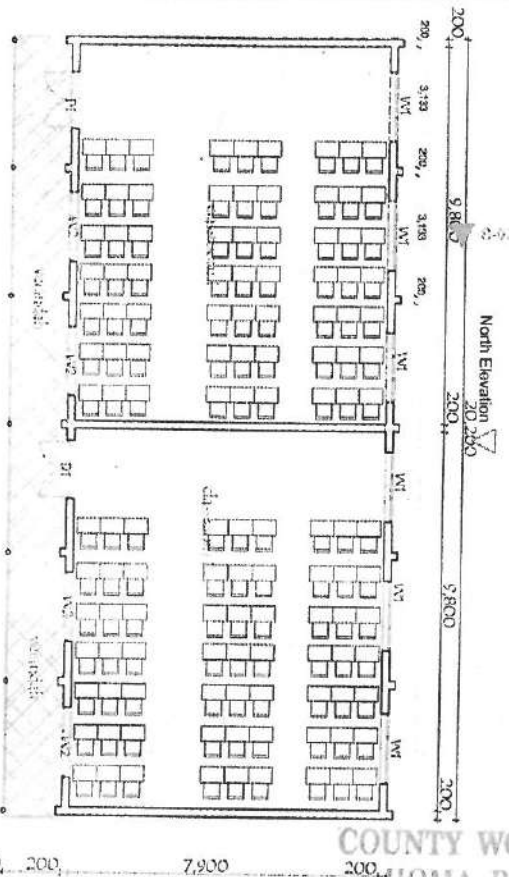
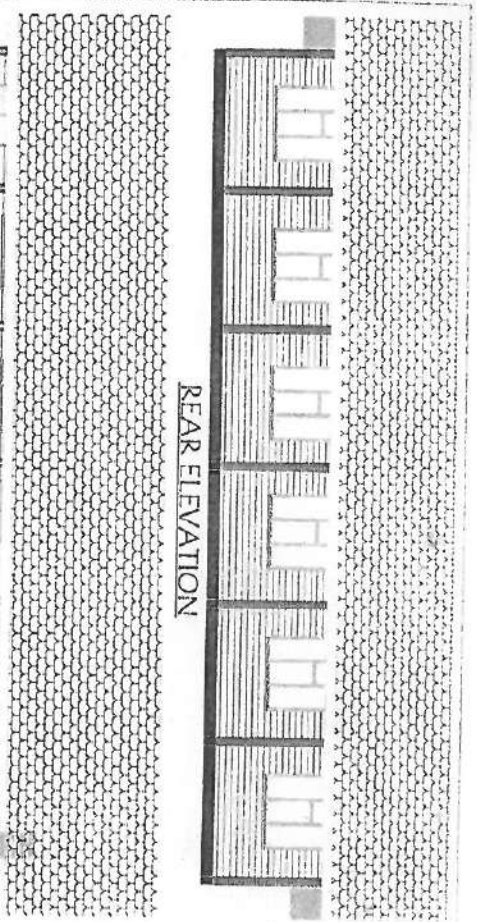

COUNTY WORKS
HOMA BAY COUNTY
P. O. Box 89-40300,
HOMA BAY

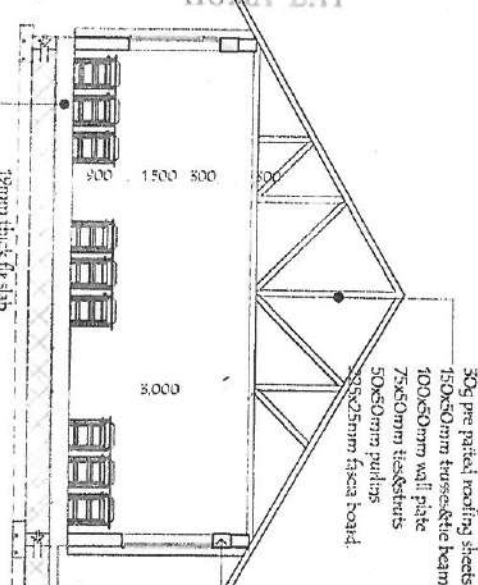
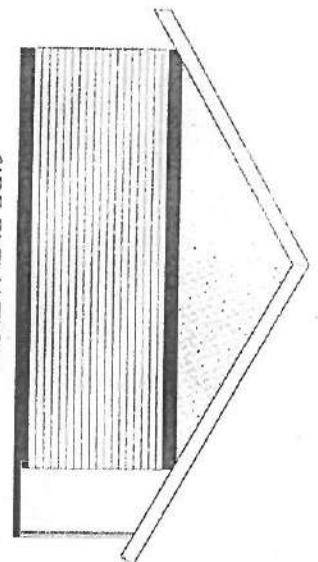

SECTION ELEVATION:
four window schedule.

W1	1500X500	Casement	6
W2	1500X900	"	4
D1	1500X2100	Steel	2

SIDE ELEVATION

- 30g pre painted roofing sheets
- 150x50mm truss/rafter beam
- 100x50mm wall plate
- 75x50mm tiebeams
- 50x50mm puddles
- 25x25mm fascia board.

NOTES:

- 1- this drawing is protected under the copyright act and cannot be used or reproduced in part or in whole.
- 2- all dimensions are in mm unless stated.
- 3- the contractor to check and verify dimensions before commencing of works and that any discrepancy to be reported to the architect.
- 4- all dimensions are to be read and not scaled.
- 5- slope to be under all walls and 150mm above g.l.
- 6- window cills must be finished before internal plaster.



MINISTRY OF ROADS,
TRANSPORT,
PUBLIC WORKS &
INFRASTRUCTURE

PROPOSED
2 NO
CLASSROOMS



Date: 2021
1400

GROUND FLOOR PLAN

FRONT ELEVATION

REAR ELEVATION

South Elevation



REPUBLIC OF KENYA



NATIONAL GOVERNMENT CONSTITUENCY DEVELOPMENT FUND
HOMA BAY TOWN CONSTITUENCY

ENGINEERS ESTIMATE

FOR

THE PROPOSED CONSTRUCTION OF 2 NO. CLASSROOMS,
AT

GOT KOKECH MIXED SECONDARY SCHOOL
IN

HOMA BAY TOWN CONSTITUENCY

PREPARED BY:

CLERK OF WORKS,

P.O BOX 240-40300,

HOMA BAY TOWN CONSTITUENCY



APPROVED BY:

SUB-COUNTY WORKS OFFICER

P.O BOX 89-40300

HOMABAY COUNTY WORKS OFFICER

HOMA BAY COUNTY

P. O. Box 89-40300,

HOMA BAY

SUMMARY

ITEM	DESCRIPTION	AMOUNT (KSHS/CTS)
I	SUBSTRUCTURE CARRIED FROM PAGE 3	583,030.00
II	SUPERSTRUCTURE CARRIED FROM PAGE 4	73,810.00
III	WALLING CARRIED FROM PAGE 5	230,310.00
IV	WINDOWS CARRIED FROM PAGE 6	95,650.00
V	DOORS CARRIED FROM PAGE 7	43,150.00
VI	ROOFING CARRIED FROM PAGE 9	404,110.00
VII	FINISHES CARRIED FROM PAGE 10	379,940.00
TOTAL FOR MEASURED WORKS CARRIED TO GRAND SUMMARY		1,810,000.00

PROPOSED CONSTRUCTION OF 2 NO. CLASSROOMS AT GOT KOKETCH MIXED SECONDARY SCHOOL

ITEM	DESCRIPTION	AMOUNT (KSHS/CTS)
<u>PRIME COST SUMS</u>		
A	Allow a provisional sum of Kenya Shilling Twenty Thousand for erection of a sign board and branding of Project in accordance with NG-CDF Board Specifications	20,000.00
B	Allow a Prime Cost Sum of Kenya Shillings Seventy Thousand for execution of electrical works.	70,000.00
TOTAL FOR PRIME COST SUMS CARRIED TO GRAND SUMMARY		90,000.00

GRAND SUMMARY		
ITEM	DESCRIPTION	AMOUNT (KSHS/CTS)
I	MEASURED WORKS	1,810,000.00
II	PRIME COST SUMS	90,000.00
	SUB-TOTAL I	1,900,000.00
III	ADD 3% FOR PROJECT MANAGEMENT COMMITTEE COST	60,000.00
III	ADD 2% FOR PROJECT MANAGEMENT	40,000.00
	GRAND SUMMARY FOR 2 NO. CLASSROOMS	KSH. 2,000,000.00

AMOUNT IN WORDS : TWO MILLION SHILLINGS ONLY

PREPARED BY :

NAME: OLIVER AKINYI

DESIGNATION : CLERK OF WORKS

SIGNATURE:

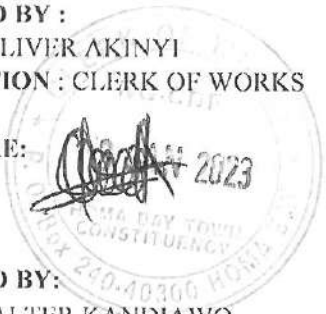

APPROVED BY:

NAME: WALTER KANDIAWO

DESIGNATION : SUB COUNTY WORKS OFFICER

SIGNATURE:

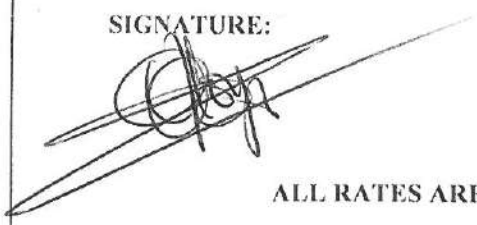

COUNTY WORKS OFFICER
HOMA BAY COUNTY
 P. O. Box 89-40300,
 HOMA BAY

ALL RATES ARE INCLUSIVE OF 16% V.A.T

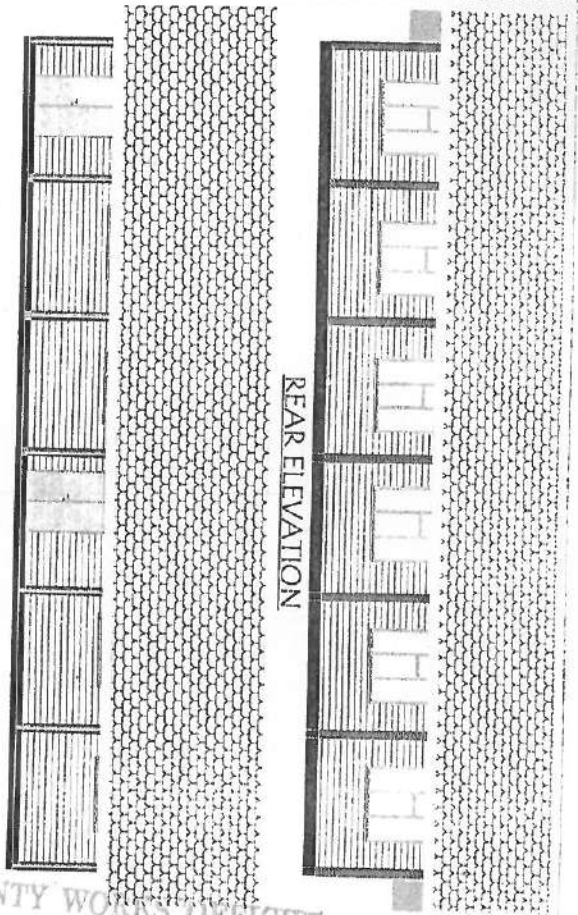

REAR ELEVATION

FRONT ELEVATION

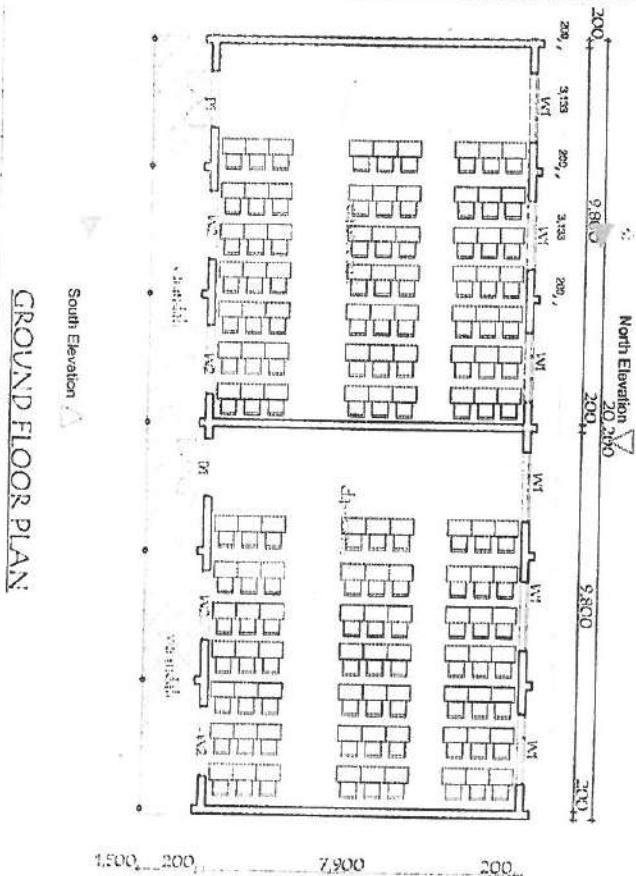

GROUND FLOOR PLAN

COUNTY WORKS OFFICES
HOMA BAY COUNTY
P. O. Box 89-40300
HOMA BAY

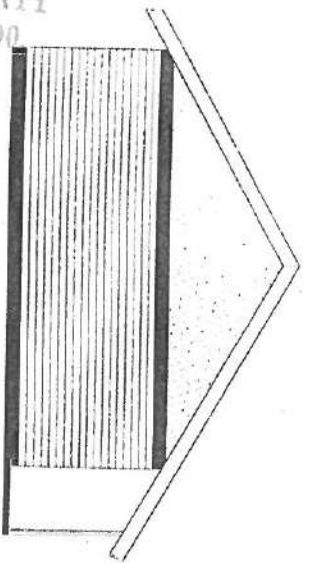

SIDE ELEVATION

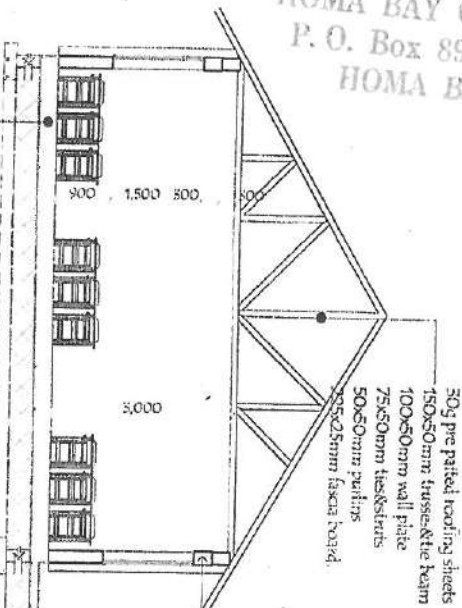

SECTION ELEVATION

footing window schedule

W1	1500X500	Casement	6
W2	1500X500	"	4
D1	1500X2500	Steel	2

- 50g pre patterned roofing sheets
- 150x50mm trusses @ 16m beam
- 100x50mm wall plate
- 75x50mm timber studs
- 50x50mm rafters
- 25x25mm fascia board

- 19mm thick fire slab
- 50mm cover if slab
- h/c mesh class A142
- 500g dpm
- approved insecticide
- 50mm spraying blinding
- 300mm hardcore filling
- h/c depth to be determined on site

NOTES:

- 1- this drawing is protected under the copyright act and cannot be used or reproduced in part or in whole.
- 2- all dimensions are in mm unless stated.
- 3- the contractor to check and verify dimensions before commencing of works and that any discrepancy to be reported to the architect.
- 4- all dimensions are to be read and not scaled.
- 5- spec to be under all walls and 150mm above g.l.
- 6- window cills must be finished before internal plaster.



MINISTRY OF ROADS,
TRANSPORT,
PUBLIC WORKS &
INFRASTRUCTURE

PROPOSED
2 NO
CLASSROOMS



DATE: 40-40300
Dec 2021 1400



REPUBLIC OF KENYA



NATIONAL GOVERNMENT CONSTITUENCY DEVELOPMENT FUND
HOMA BAY TOWN CONSTITUENCY

ENGINEERS' ESTIMATE

FOR

THE PROPOSED CONSTRUCTION OF A DORMITORY
AT

ST. THERESAS NYAUU GIRLS SECONDARY SCHOOL
IN

HOMA BAY TOWN CONSTITUENCY

PREPARED BY:

CLERK OF WORKS,

P.O BOX 240-40300,

HOMA BAY TOWN CONSTITUENCY



APPROVED BY

SUB-COUNTY WORKS OFFICER

P.O BOX 89-40300

HOMABAY

SUMMARY

ITEM	DESCRIPTION	AMOUNT (KSHS/CTS)
I	SUBSTRUCTURE CARRIED FROM PAGE 3	1,021,180.00
II	SUPERSTRUCTURE CARRIED FROM PAGE 4	177,580.00
III	WALLING CARRIED FROM PAGE 5	239,400.00
IV	WINDOWS CARRIED FROM PAGE 6	211,300.00
V	DOORS CARRIED FROM PAGE 7	78,600.00
VI	ROOFING CARRIED FROM PAGE 9	668,610.00
VII	FINISHES CARRIED FROM PAGE 10	668,868.00
TOTAL FOR MEASURED WORKS CARRIED TO GRAND SUMMARY		3,065,538.00

PROPOSED CONSTRUCTION OF DORMITORY AT ST. THERESAS NYAUU GIRLS SECONDARY SCHOOL

ITEM	DESCRIPTION	AMOUNT (KSHS/CTS)
<u>PRIME COST SUMS</u>		
A	Allow a provisional sum of Kenya Shillings Twenty Thousand for erection of a sign board and branding of Project in accordance with NG-CDF Board Specifications	20,000.00
B	Allow a provisional sum of Two Hundred Thousand for electrical works to the 4 No. Classrooms	200,000.00
C	Allow a provisional sum of Forty Thousand shillings for construction of a ramp for access of people with disability	40,000.00
TOTAL FOR PRIME COST SUMS CARRIED TO GRAND SUMMARY		260,000.00

PROPOSED CONSTRUCTION OF DORMITORY AT ST. THERESAS NYAUU GIRLS SECONDARY SCHOOL

GRAND SUMMARY

ITEM	DESCRIPTION	AMOUNT (KSHS/CTS)
I	MEASURED WORKS	3,065,538.00
II	PRIME COST SUMS	260,000.00
	SUB-TOTAL I	3,325,538.00
III	ADD 3% FOR PROJECT MANAGEMENT COMMITTEE COST	104,462.00
III	ADD 2% FOR PROJECT MANAGEMENT	70,000.00
	GRAND SUMMARY FOR 2 NO. CLASSROOMS	3,500,000.00

AMOUNT IN WORDS : THREE MILLION FIVE HUNDRED THOUSAND SHILLINGS ONLY

PREPARED BY :

NAME: OLIVER AKINYI

DESIGNATION : CLERK OF WORKS

SIGNATURE:

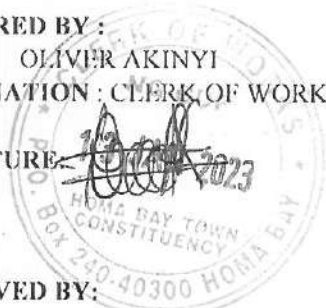

APPROVED BY:

NAME: WALTER KANDIAWO

DESIGNATION : SUB COUNTY WORKS

OFFICER

SIGNATURE:

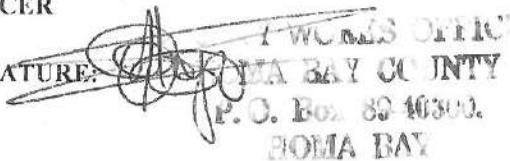

ALL RATES ARE INCLUSIVE OF 16% V.A.T

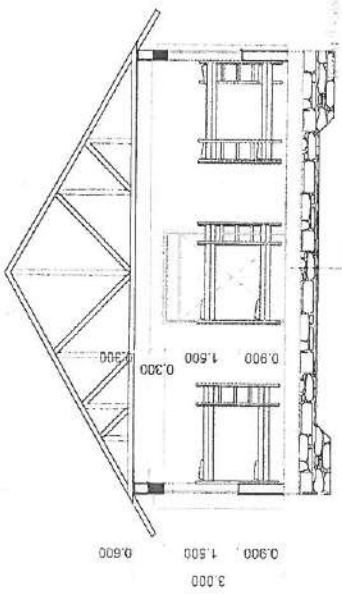

SECTION ELEVATION

1. All dimensions in mm
 2. All dimensions to face
 3. All dimensions to centerline
 4. All dimensions to be confirmed
 5. All dimensions to be confirmed

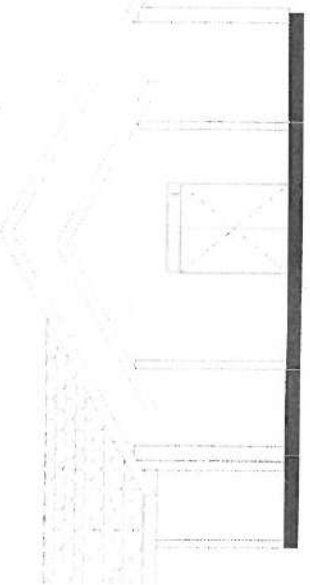

SIDE ELEVATION



FRONT ELEVATION

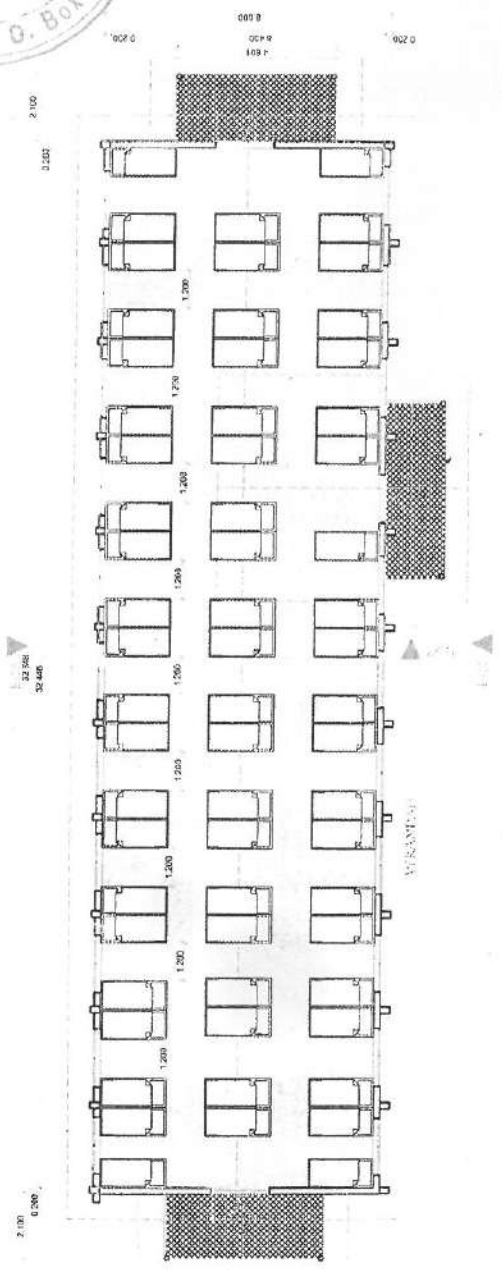

GROUND FLOOR PLAN

NOTES:

- all dimensions are mm.
- scaled dimensions not to be used.
- all structural works to the approval of SE.
- foundation designed for allowable safe bearing capacity of 125kn/m2
- minimum conc cover to reinforcement beams-----25mm
- slabs-----20mm
- columns----40mm
- substructures-50mm
- reinforcement cut,bent and scheduled to BS 4446 .
- grid setting out dimensions to be confirmed by the SE.



MINISTRY OF ROADS,
 TRANSPORT,
 PUBLIC WORKS &
 INFRASTRUCTURE



PROJECT:

SCHOOL DORMITORY

CLIENT:

ST THERESA'S NYAUU GIRLS
 SEC SCHOOL